

Mountfield

FINSKÁ SAUNA / FÍNSKA SAUNA

SUVI

46828

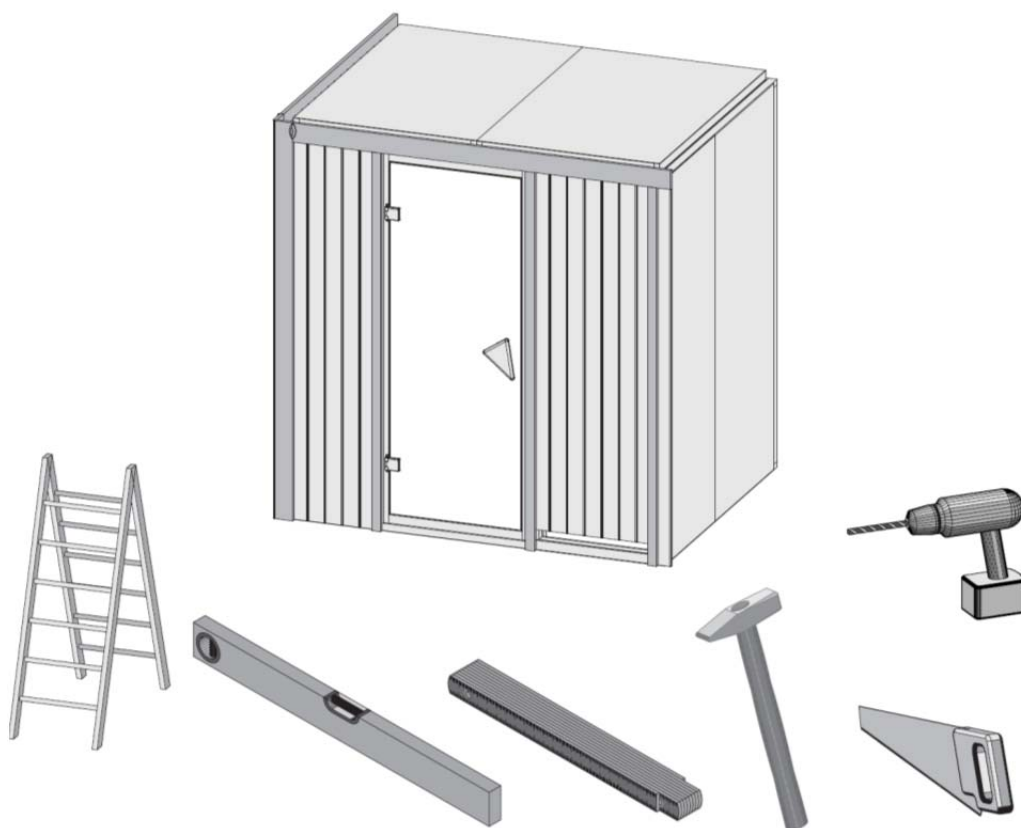

NÁVOD NA MONTÁŽ

DOPORUČENÍ / ODPORÚČANIE:

Montáž:	2 dospělé osoby	2 dospelé osoby
Elektroinstalace:	elektrický přívod musí odpovídat požadavkům na pevné připojení spotřebiče (viz požadavky na elektroinstalaci finské sauny);	elektrický prívod musí odpovedať požiadavkám na pevné pripojenie spotrebiča (viď požiadavky na elektroinštaláciu fínskej sauny);
Elektroinštalácia:	veškeré elektroinstalační práce musí provádět osoba s příslušnou elektrotechnickou kvalifikací	všetky elektroinštalačné práce musí vykonávať osoba s príslušnou elektrotechnickou kvalifikáciou

Doporučený postup při montáži Odporúčaný postup pri montáži

1 – krok	<p>Kontrola kompletnosti sauny podle specifikace všech dílů (viz přehled dále).</p> <p>Pokud dojde ke zjištění chybějícího dílu, zaškrtněte prosím chybějící díl v návodu a zašlete nám jeho identifikační číslo, díl Vám bude neprodleně zaslán.</p>	<p>Kontrola kompletnosti sauny podľa špecifikácie všetkých dielov (viď prehľad ďalej).</p> <p>Pokiaľ dôjde k zisteniu chýbajúceho dielu, zaškrtnite prosím chýbajúci diel v návode a zašlite nám jeho identifikačné číslo, diel Vám bude bezodkladne zaslaný.</p>
2 – krok	<p>Zabezpečení proti poškození.</p> <p>Ubezpečte se, že saunové dveře jsou bezpečně uloženy a nehrozí jejich poškrábání nebo rozbití.</p>	<p>Zabezpečenie proti poškodeniu.</p> <p>Ubezpečte sa, že saunové dvere sú bezpečne uložené a nehrozí ich poškrabanie alebo rozbitie.</p>
3 – krok	<p>Sestavení základního saunového rámu.</p> <p>Dbejte na ideální rovinu rámu, kterou zkontrolujete pomocí vodováhy. Pokud nebude rám v ideální rovině, vzniknou problémy s montáží rámu dveří.</p>	<p>Zostavenie základného saunového rámu.</p> <p>Dbajte na ideálnu rovinu rámu, ktorú skontrolujete pomocou vodováhy. Pokiaľ nebude rám v ideálnej rovine, vzniknú problémy s montážou rámu dverí.</p>
4 – krok	<p>Montáž sauny podle návodu.</p>	<p>Montáž sauny podľa návodu.</p>
5 – krok	<p>Volba varianty otevírání dveří.</p> <p>Při montáži si zvolíte variantu levé / pravé dveře, která Vám bude vyhovovat.</p>	<p>Voľba varianty otvárania dverí.</p> <p>Pri montáži si zvolíte variantu ľavé / pravé dvere, ktorá Vám bude vyhovovať.</p>
6 – krok	<p>Vizuální kontrola vzhledu sauny, případné dočištění dřeva od oděrek.</p>	<p>Vizuálna kontrola vzhľadu sauny, prípadné dočistenie dreva od oderov.</p>

Nejprve porovnejte uvedený seznam dílů s obsahem balení! Pochopte prosím, že stížnosti mohou být zpracovány pouze v nesestaveném stavu!

Najprv porovnajzte uvedený zoznam dielov s obsahom balenia! Pochopzte prosím, že sťažnosti môžu byť spracované len v nezostavenom stave!



46828

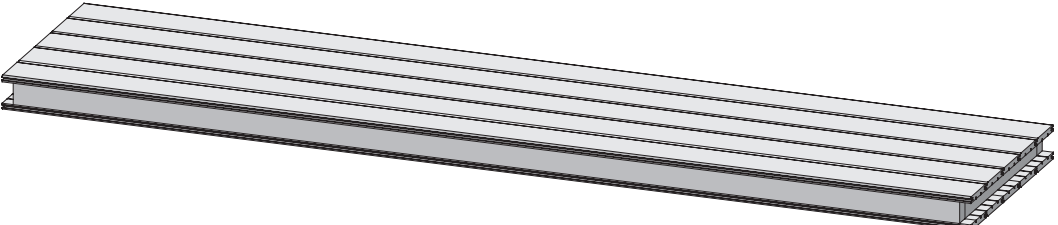

1 x W1	1920 x 433 x 68mm	ID 25547
1 x W2	1920 x 606 x 68mm	ID 25548
1 x W3	1920 x 780 x 68mm	ID 25549

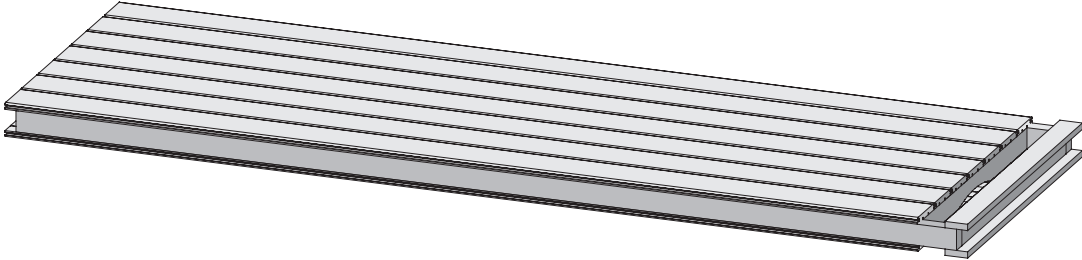

1 x W4	1920 x 606 x 68mm	ID 25550
--------	-------------------	----------

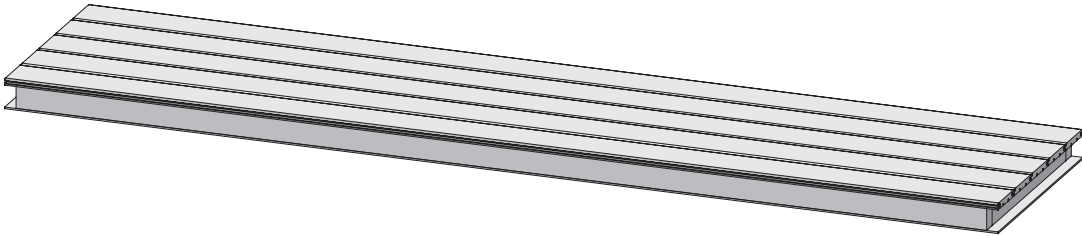

3 x W5	1920 x 606 x 57mm	ID 23624
1 x W6	1920 x 780 x 57mm	ID 23625

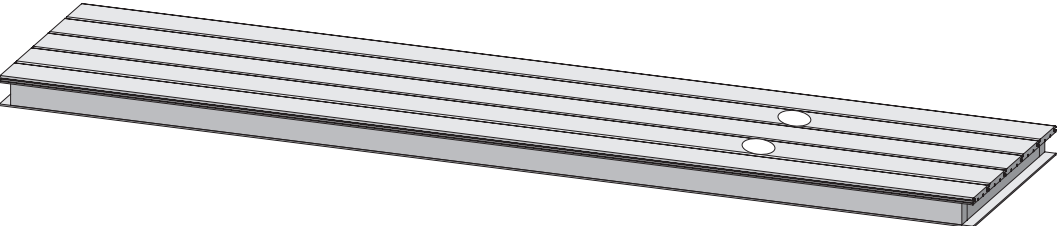

1 x W7	1920 x 606 x 57mm	ID 23629
--------	-------------------	----------

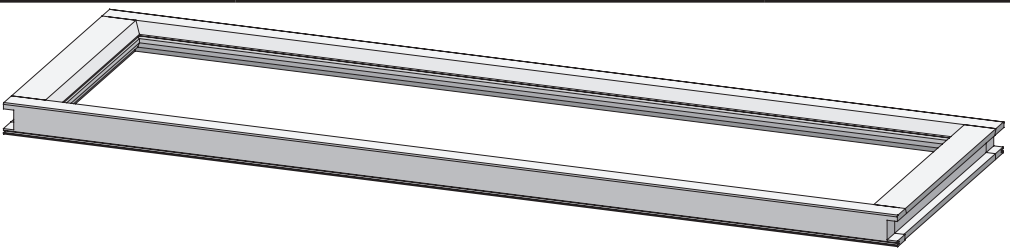

1 x W8	1872 x 780 x 42mm	ID 25551
--------	-------------------	----------

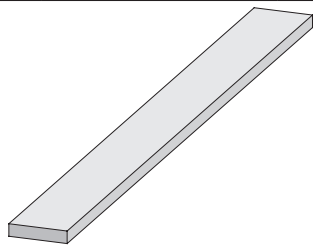

5 x B1	1920 x 19 x 3mm	ID 20799
4 x B2	750 x 36 x 12mm	ID 24239
4 x B3	1920 x 36 x 12mm	ID 24846
5 x B4	1884 x 45 x 17mm	ID 48037
4 x B5	70 x 45 x 18mm	ID 26366
4 x B6	800 x 45 x 18mm	ID 24796
4 x B7	480 x 95 x 18mm	ID 20930
4 x B8	580 x 95 x 18mm	ID 16708
1 x B9	1505 x 95 x 18mm	ID 26398
1 x B10	1895 x 95 x 18mm	ID 39324
1 x B11	300 x 120 x 18mm	ID 22467
2 x B12	551 x 42 x 28mm	ID 24053
2 x B13	774 x 42 x 28mm	ID 24112
2 x B14	1382 x 42 x 28mm	ID 24107
4 x B15	1492 x 42 x 28mm	ID 26397
2 x B16	1756 x 42 x 28mm	ID 24131
4 x B17	1841 x 42 x 28mm	ID 26376
3 x B18	1874 x 52 x 52mm	ID 26165

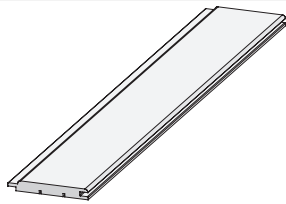

2 x E1	1920 x 97 x 12mm	ID 22863
--------	------------------	----------

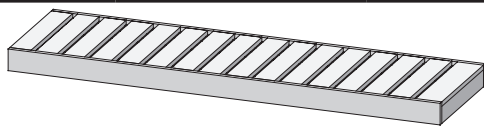

1 x L1	1810 x 250 x 90mm	ID 44617
1 x L2	1810 x 550 x 90mm	ID 21767

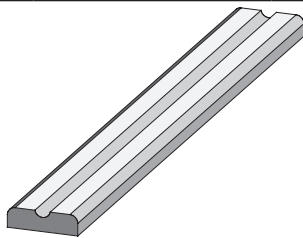

2 x L3	1810 x 90 x 22mm	ID 26112
--------	------------------	----------

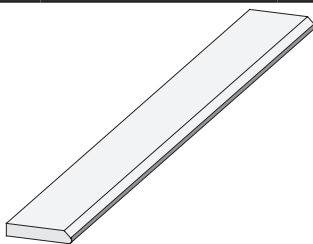

2 x G1	1980 x 95 x 17mm	ID 48540
--------	------------------	----------

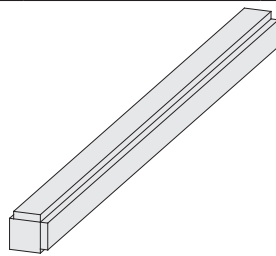

1 x K1	1874 x 64 x 64mm	ID 24725
--------	------------------	----------

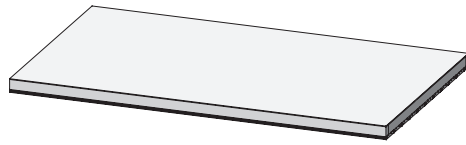

2 x M1	1406 x 918 x 57mm	ID 46970
--------	-------------------	----------

1 x

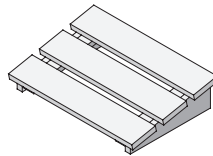

ID 25545

10m

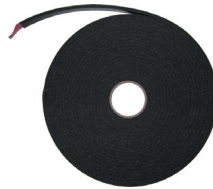

ID 14025



190 x	4 x 30mm	ID 3686
30 x	4 x 40mm	ID 21925
80 x	4 x 50mm	ID 3688
50 x	4 x 70mm	ID 3689
80 x	4,5 x 80mm	ID 9204
40 x	6 x 60mm	ID 14014



120 x	4,5 x 40mm	ID 26285
-------	------------	----------

6 x S1



ID 14266



120 x S2	4,5 x 30mm	ID 26116
6 x S3	12 x 18mm	ID 46403

4 x T1

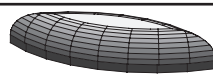

ID 26272

20 x



ID 14005

1 x

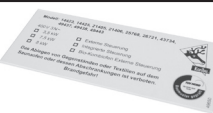

ID 49867

2 x

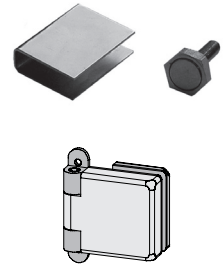

ID 26496

1 x

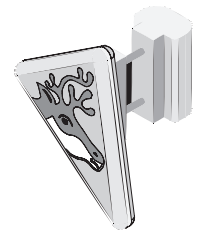

ID 26114

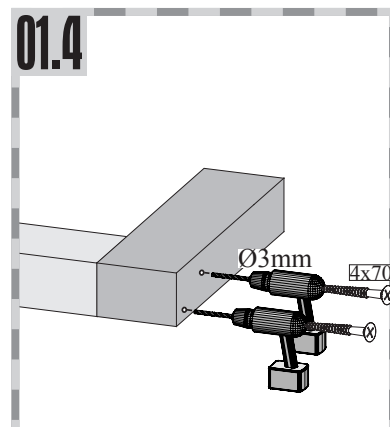
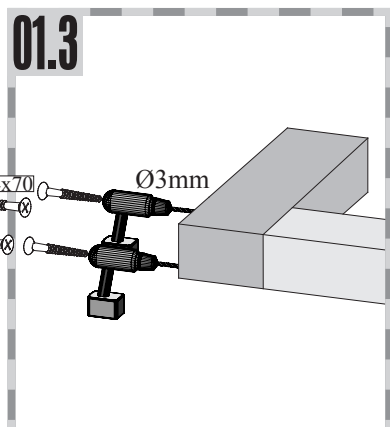
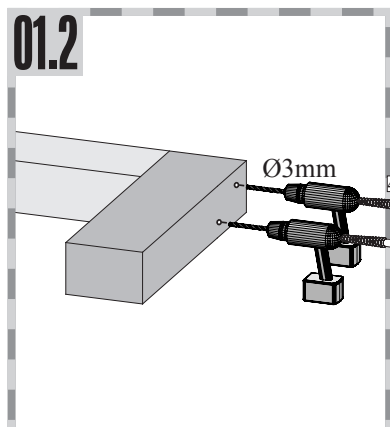
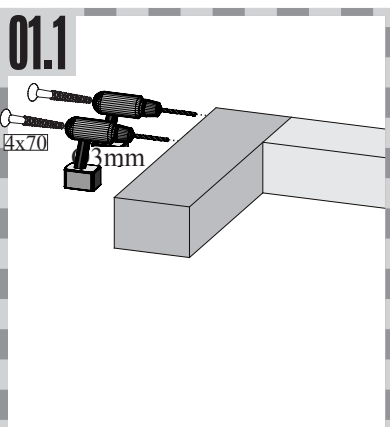
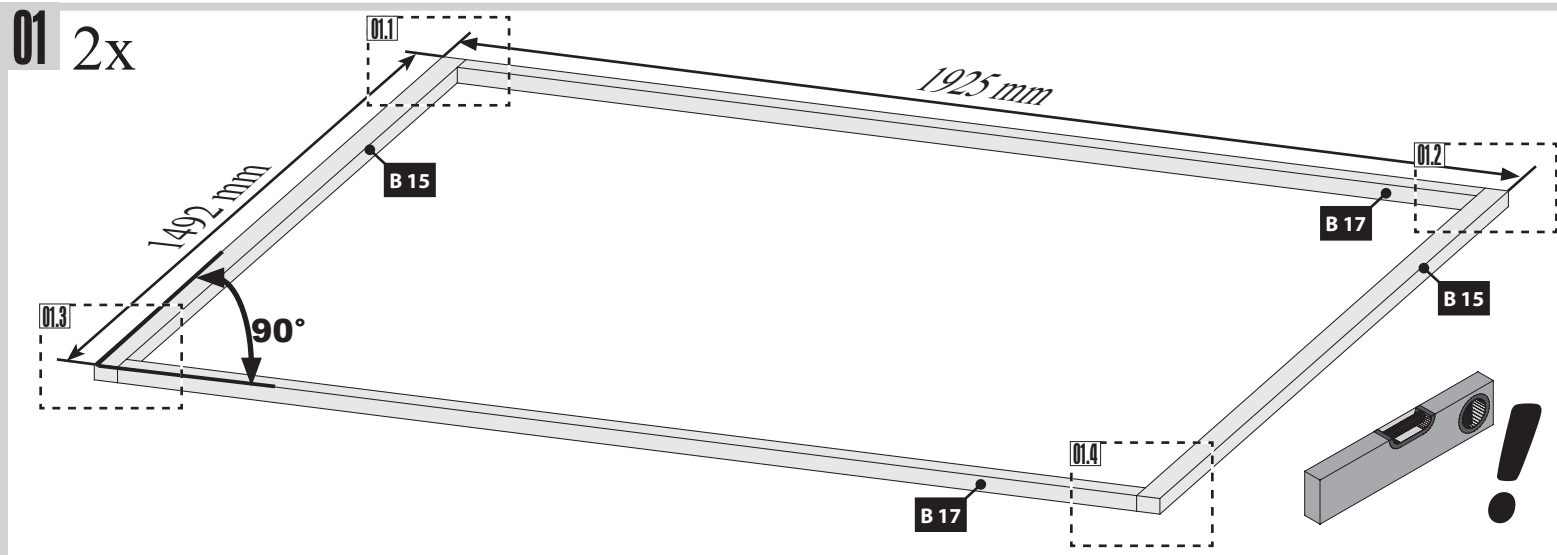
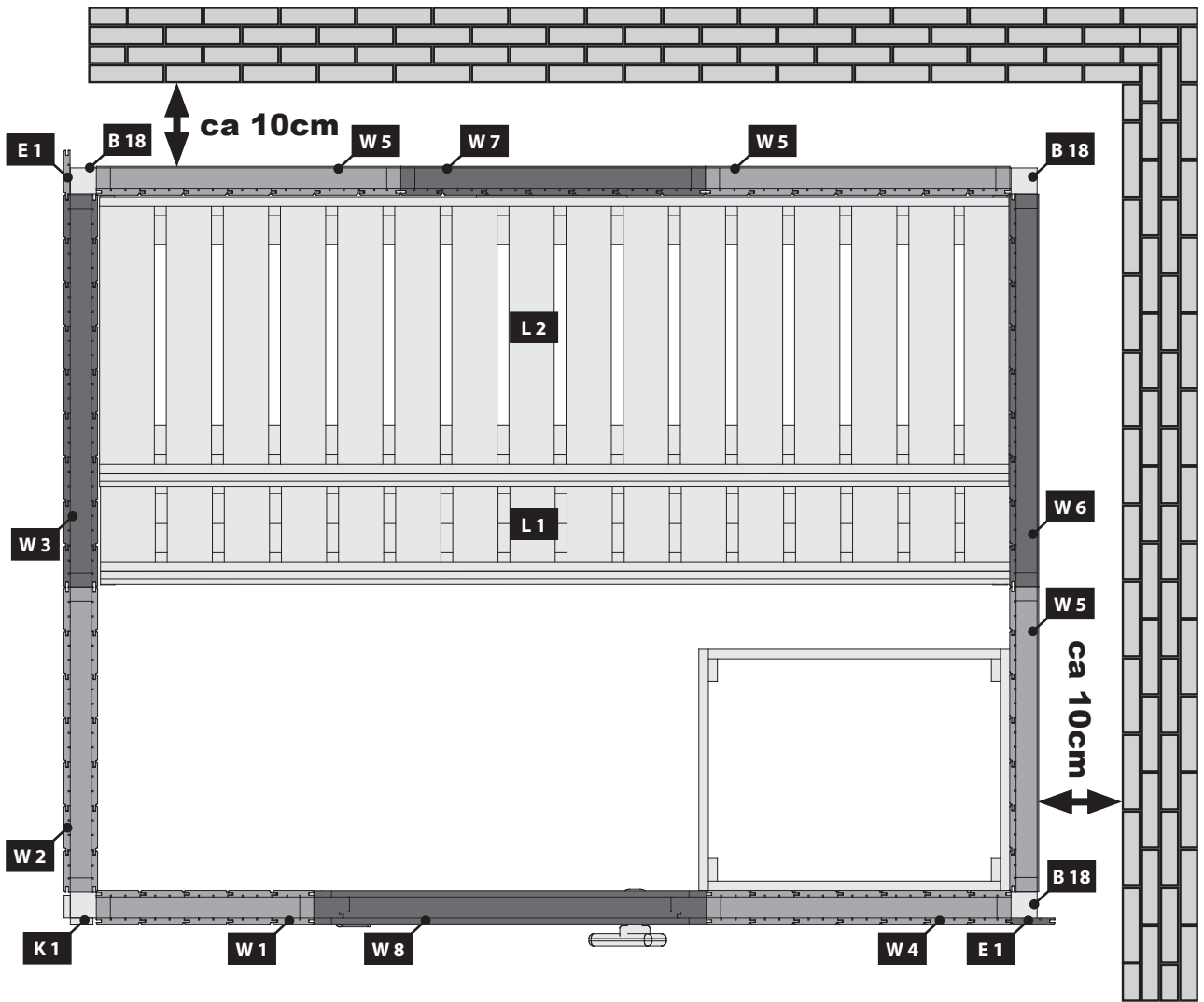

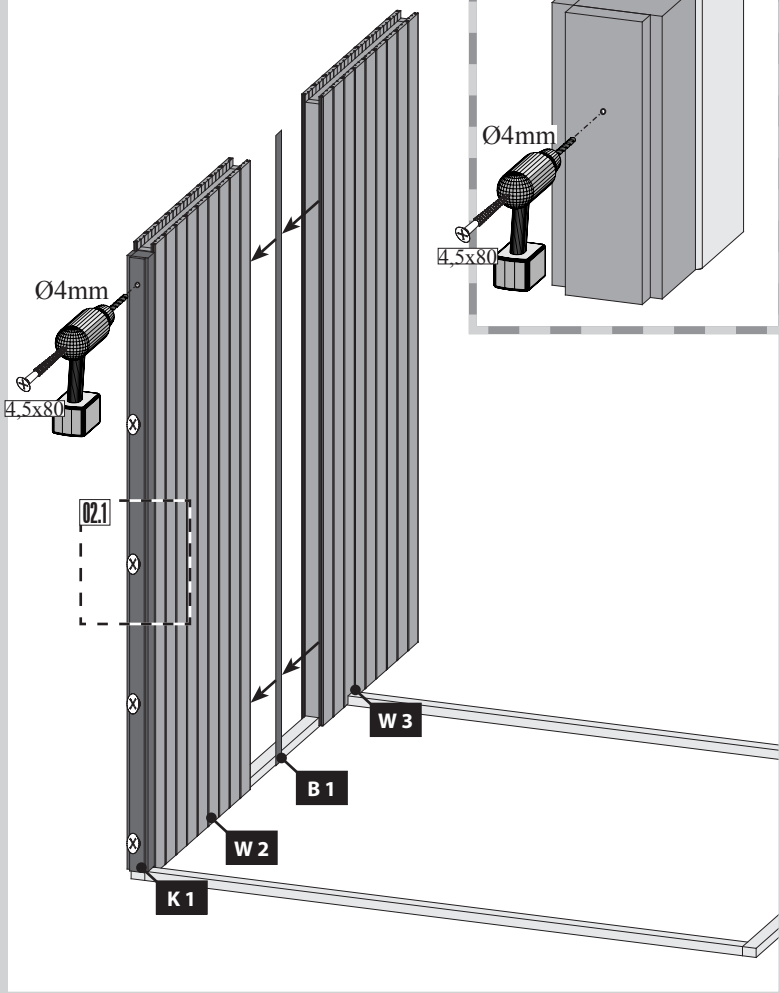
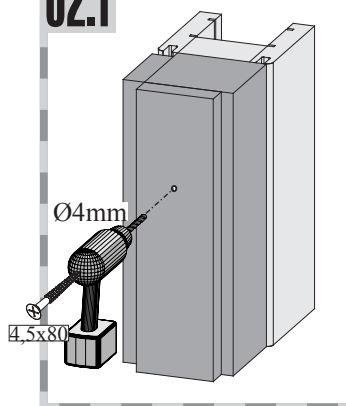
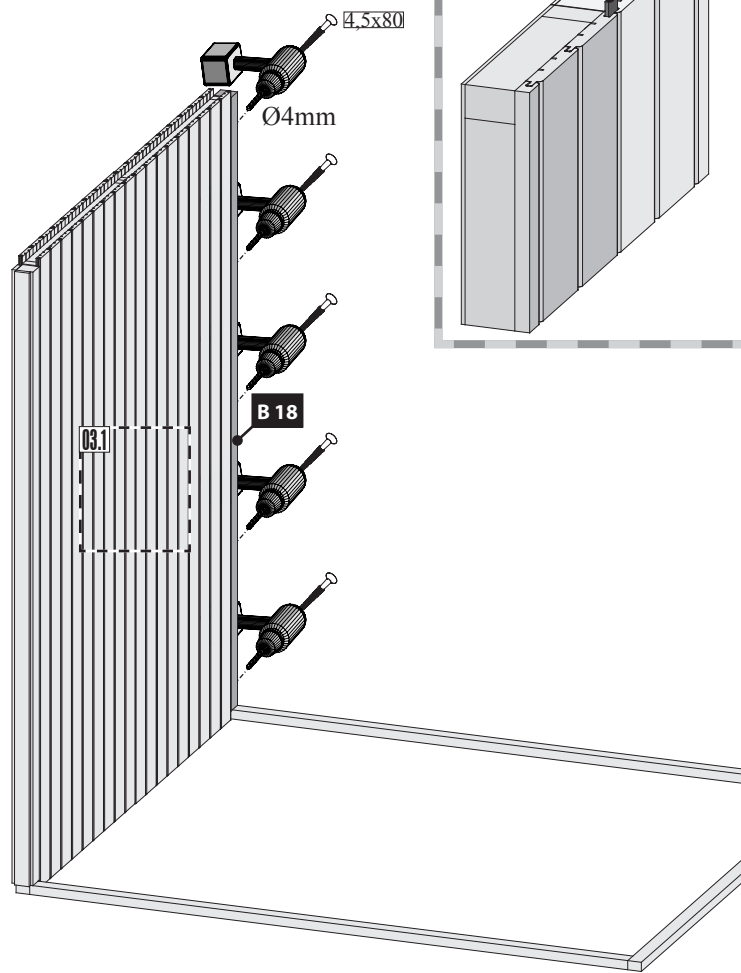
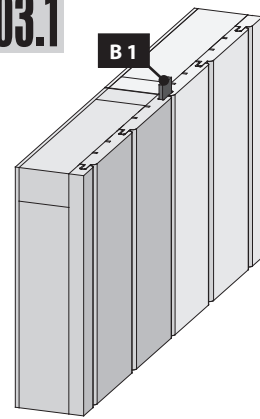
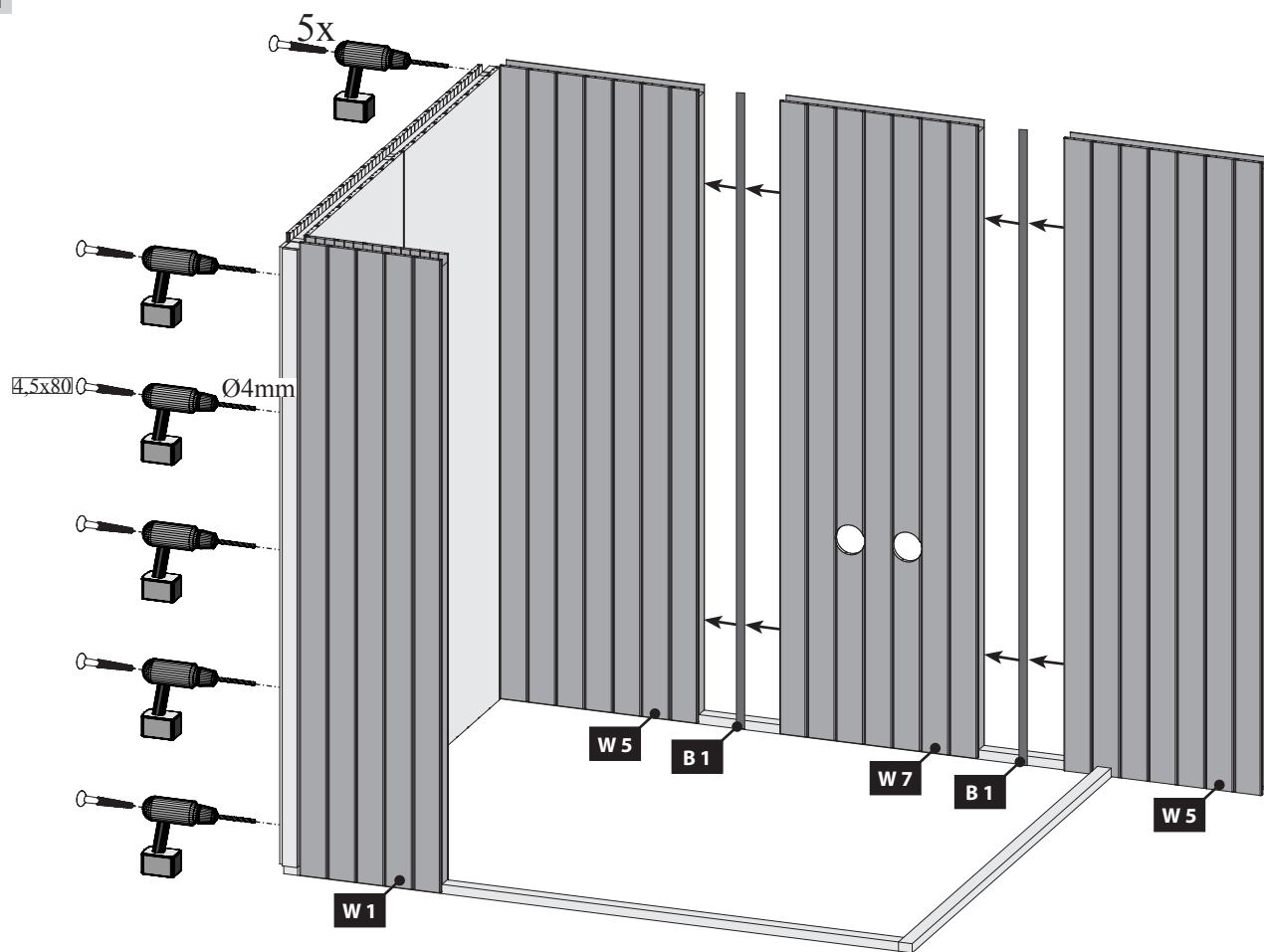
02**02.1****03****03.1****04**

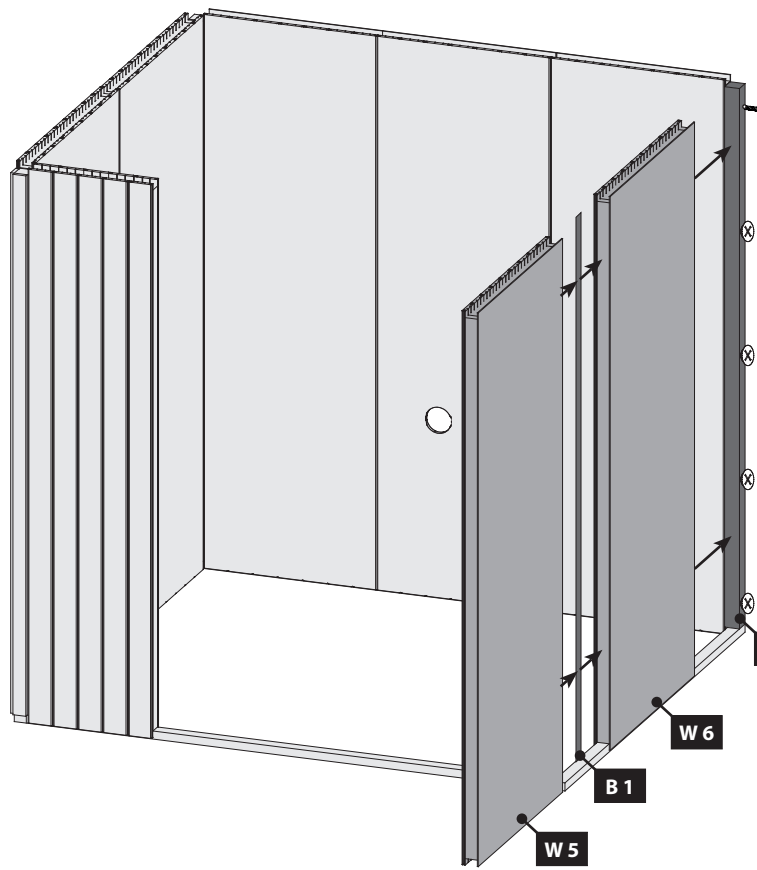
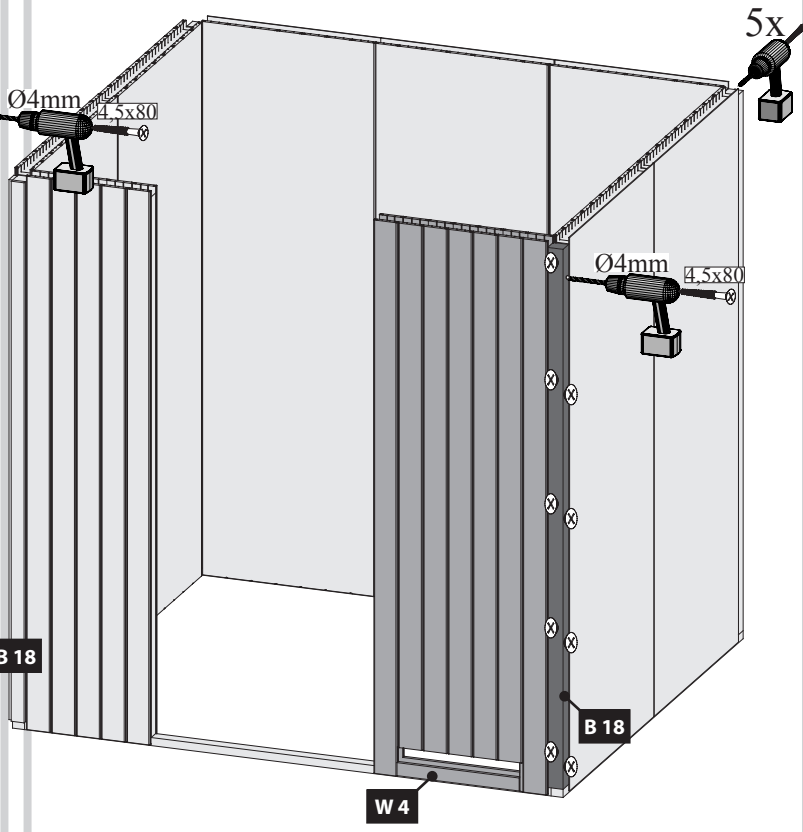
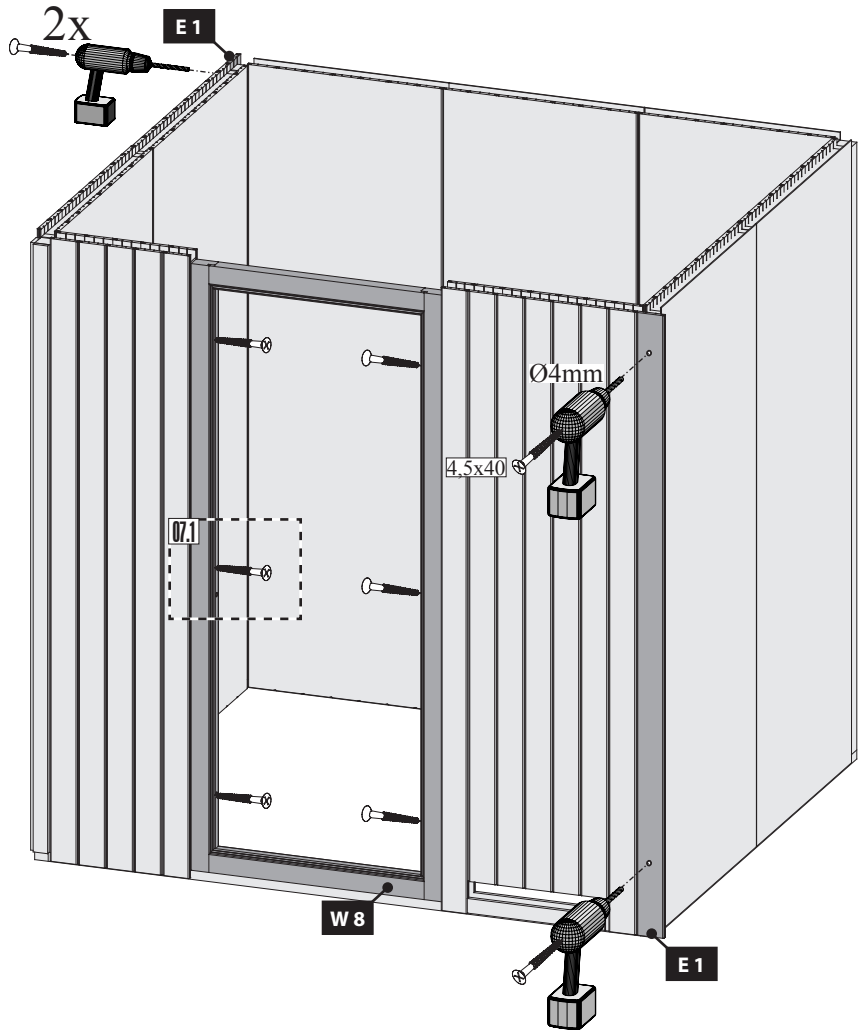
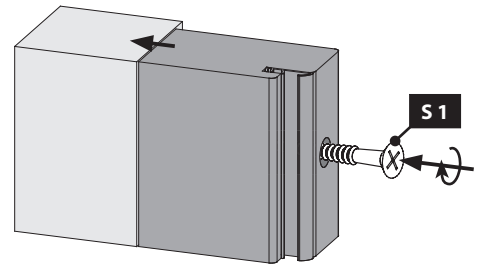
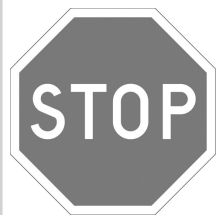
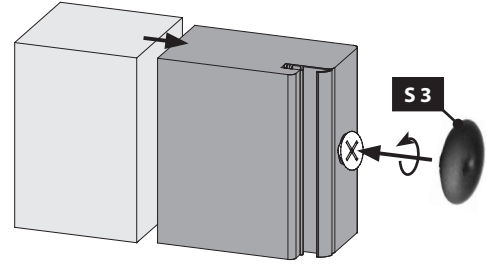
05**06****07****07.1-1****07.1-2**

Nyní sestavte skleněné
dvěře - viz dále.

Teraz zostavte sklenené
dvere - viď ďalej.

!!! 01 — 03 !!!

08

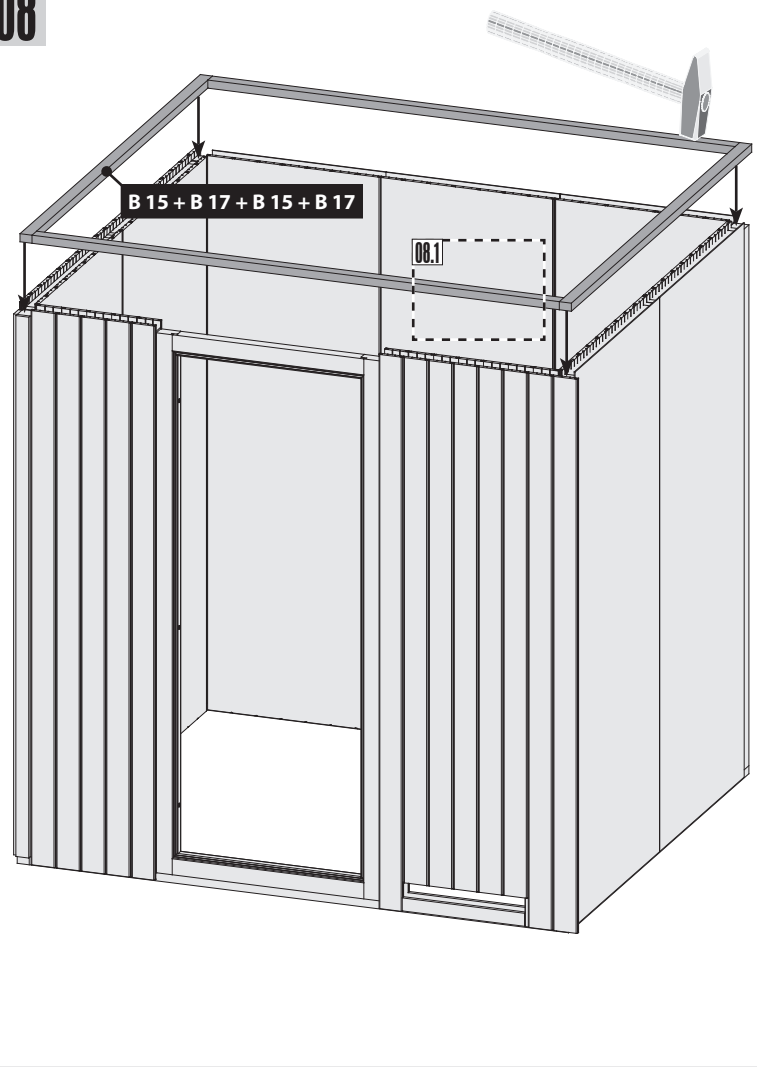

09

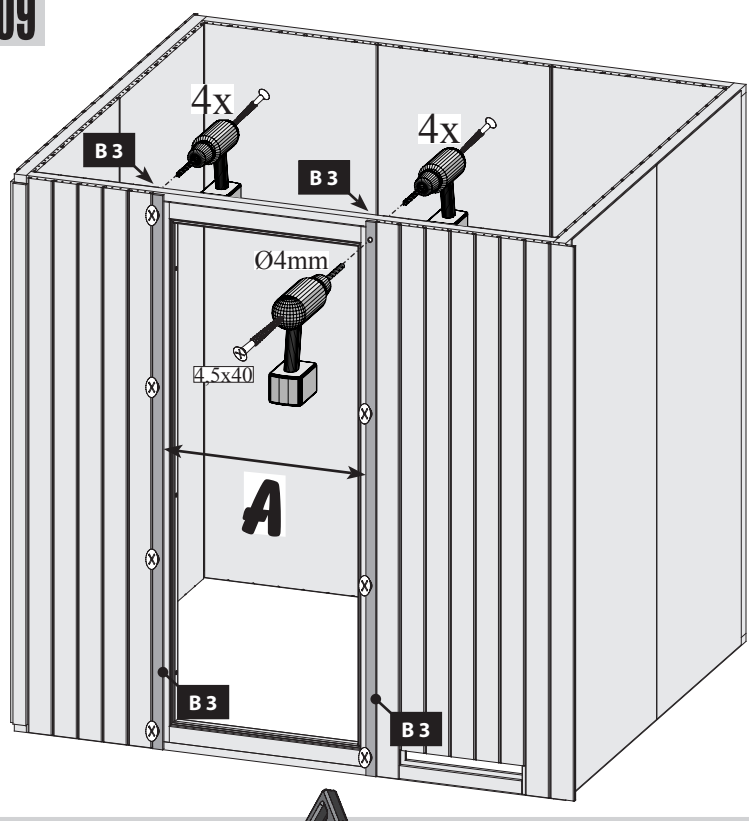

08.1

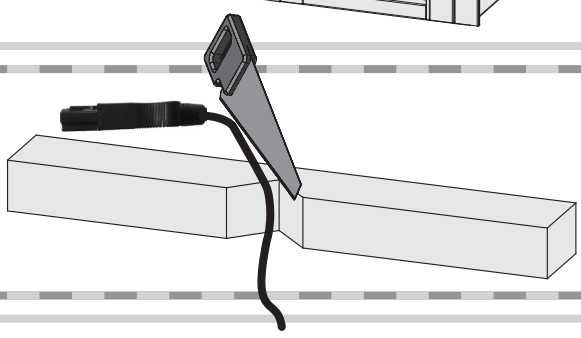

10

4x

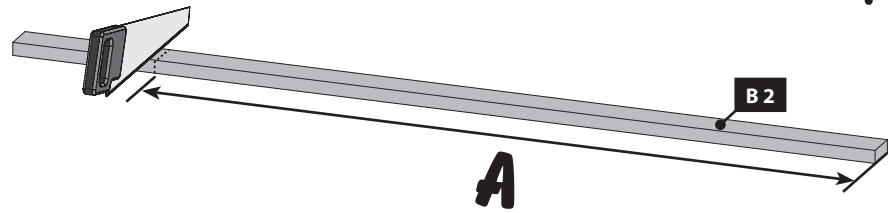

11

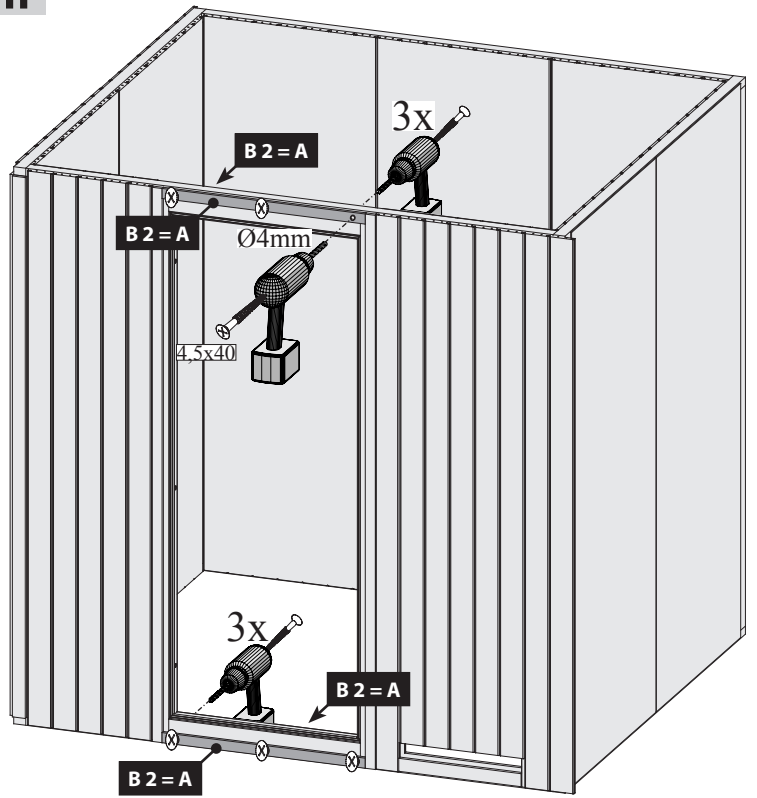

12

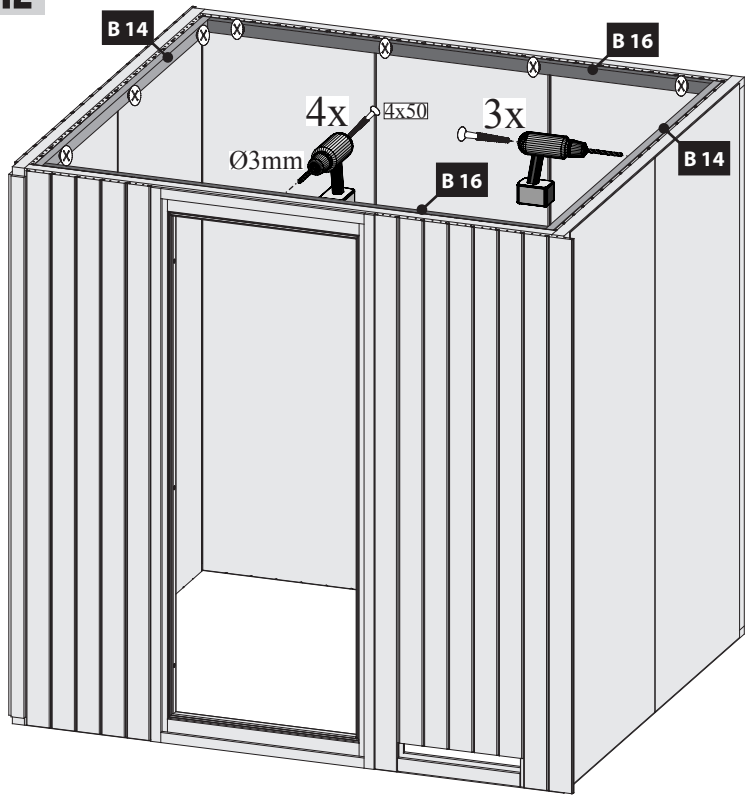

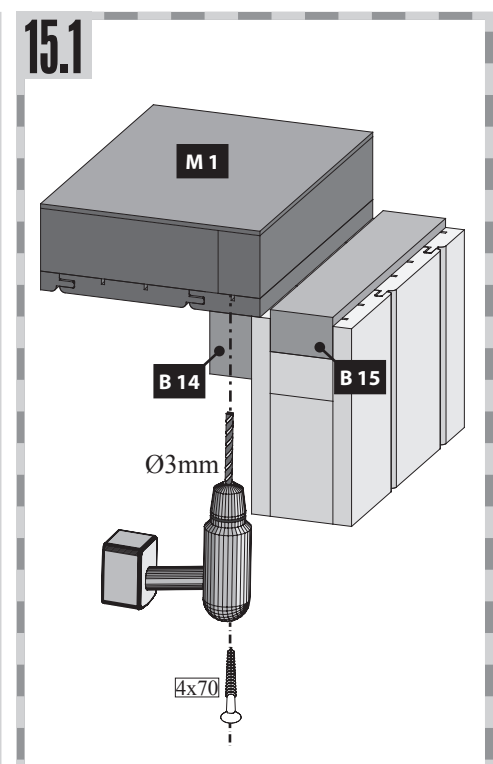
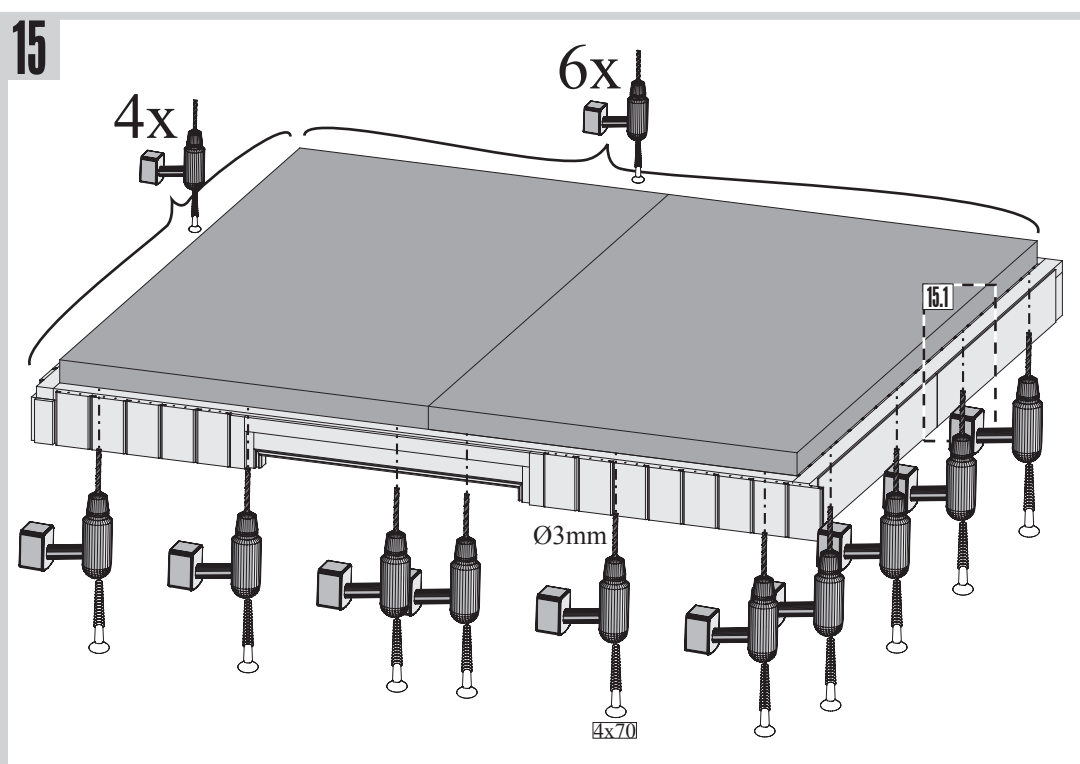
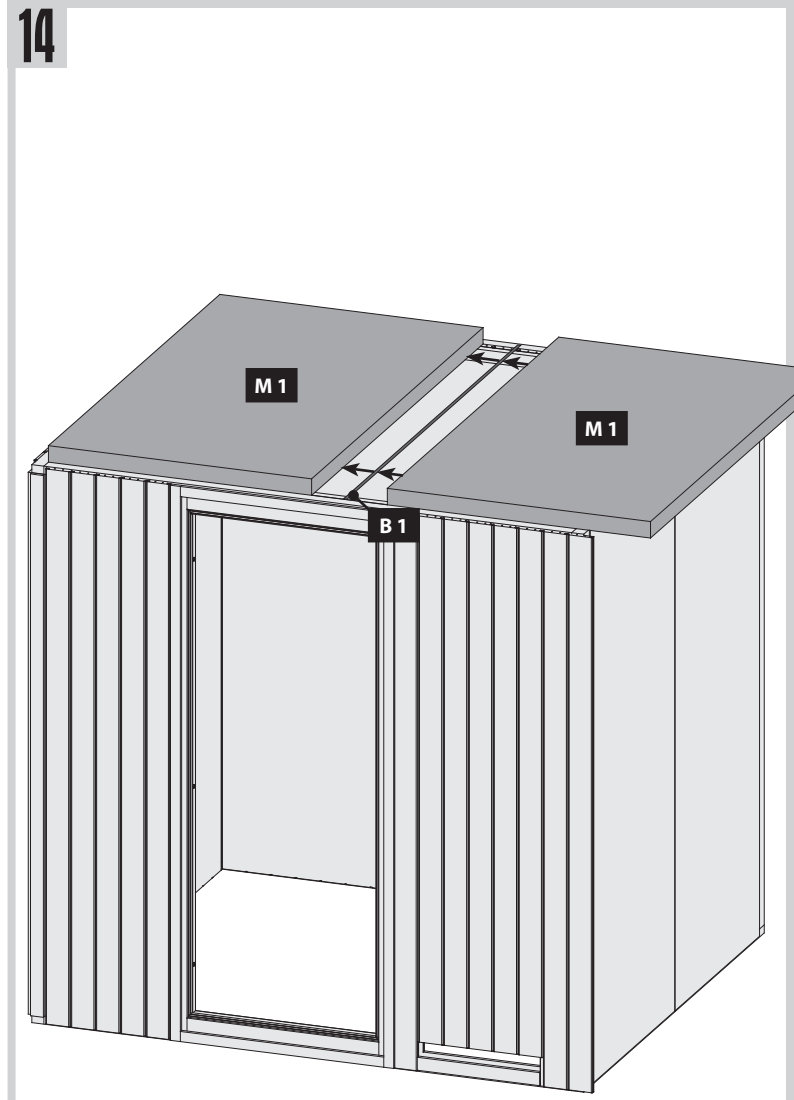
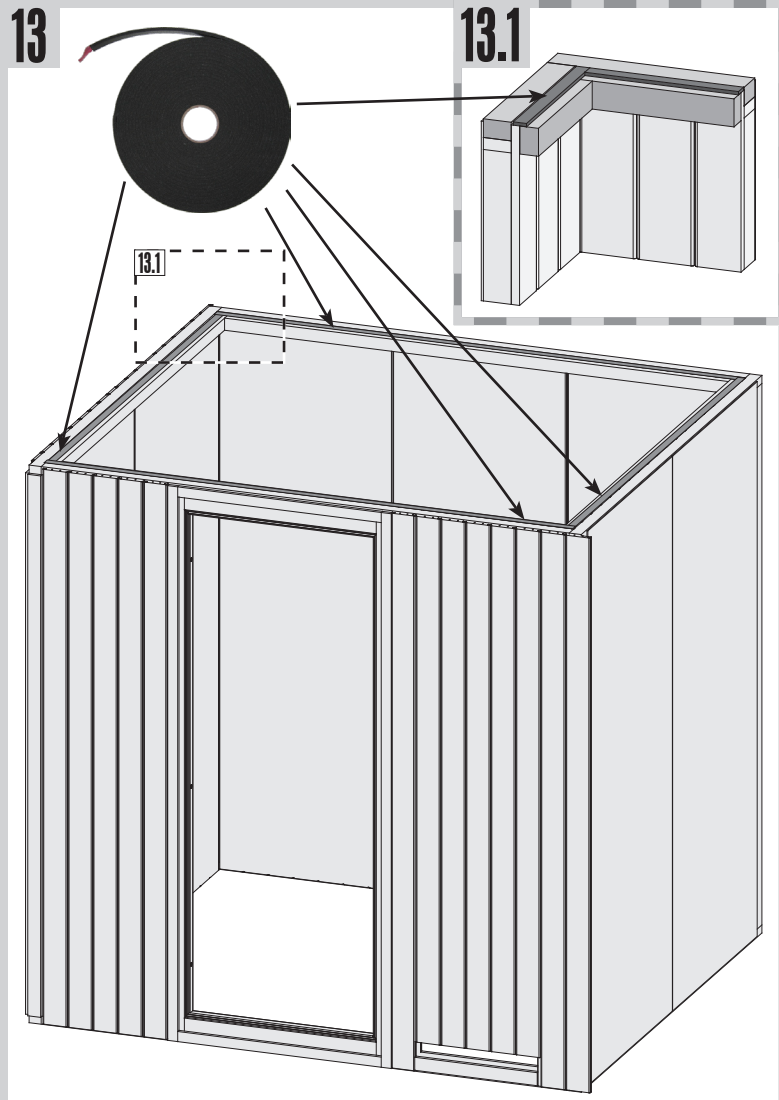

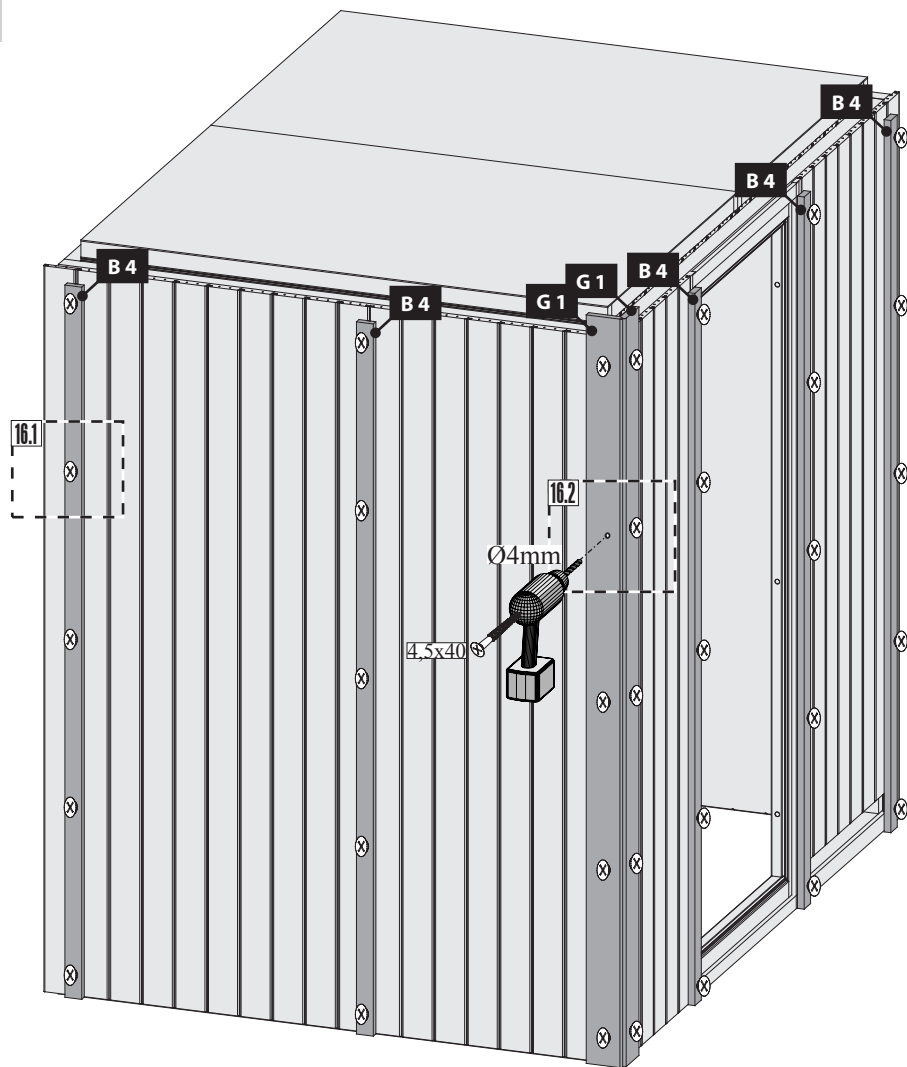
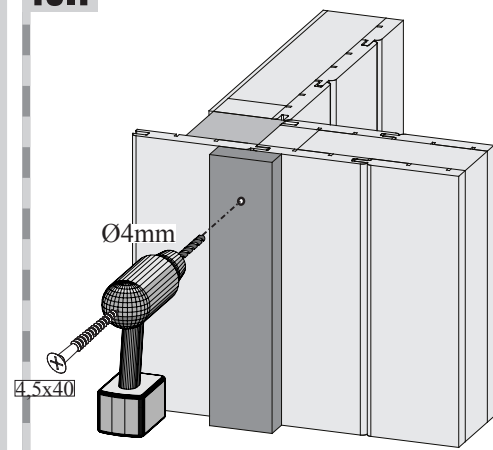
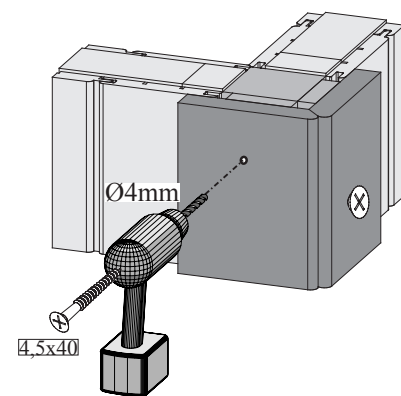
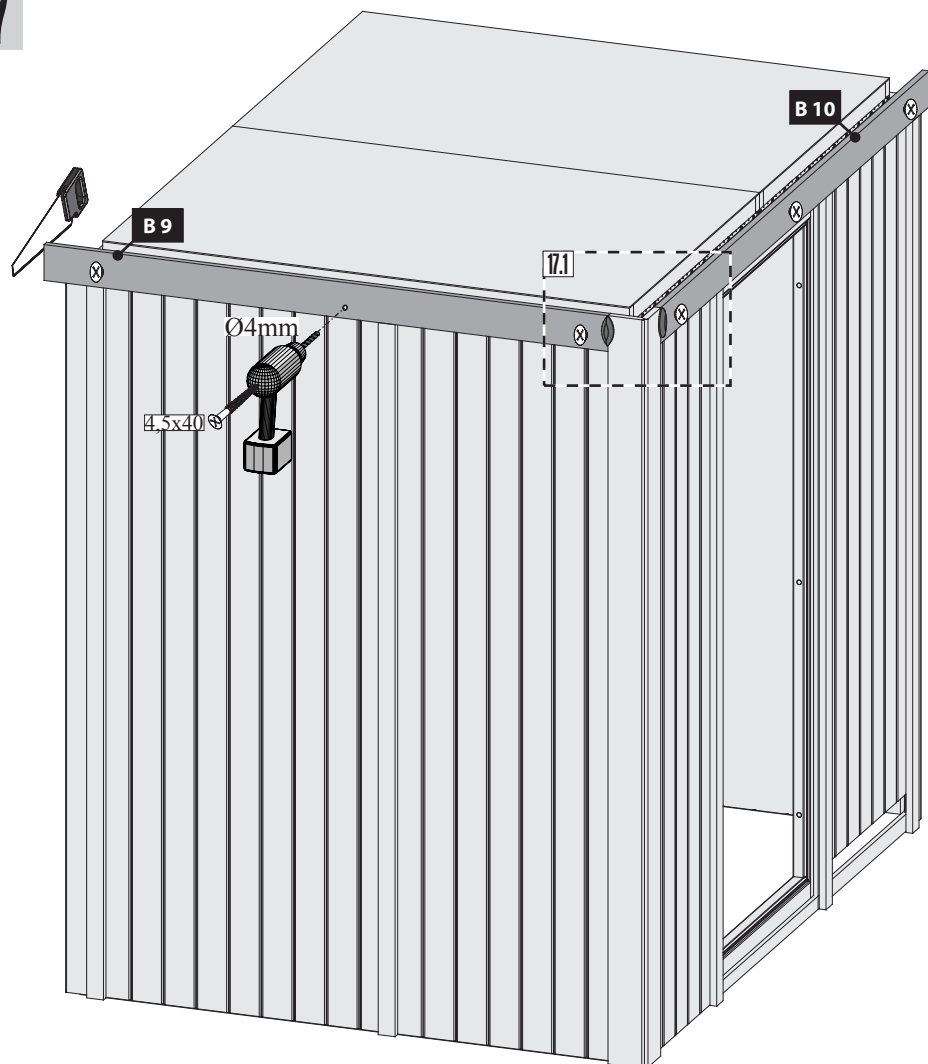
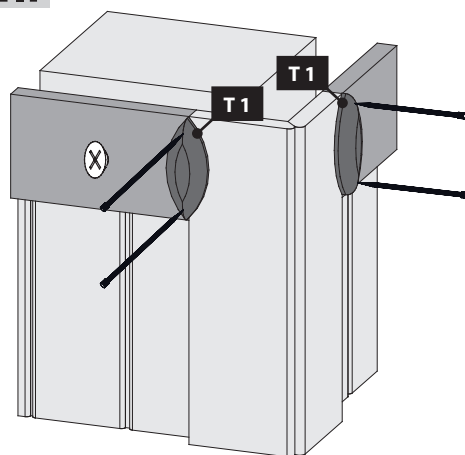
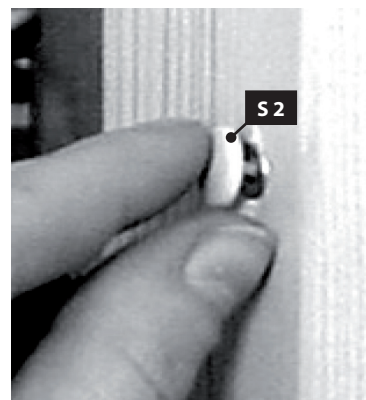
16**16.1****16.2****17****17.1****18**

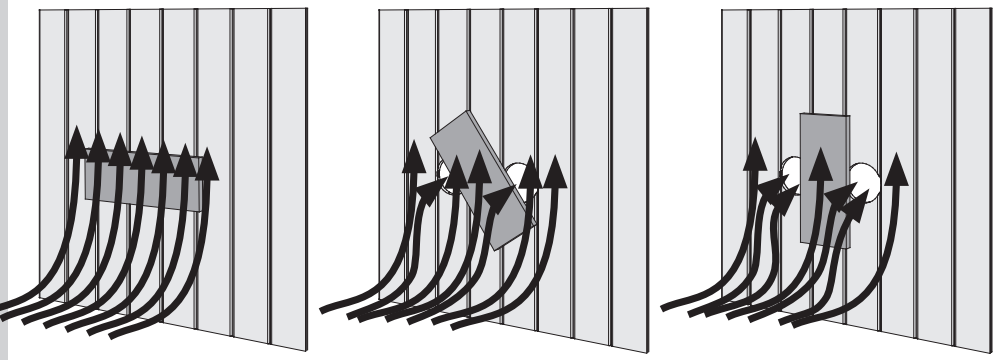
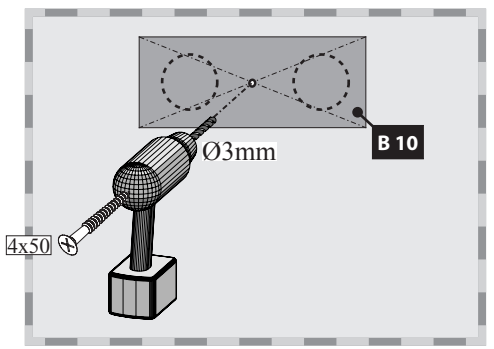
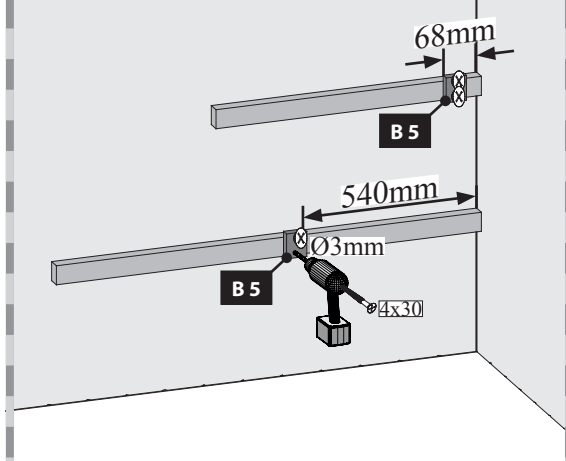
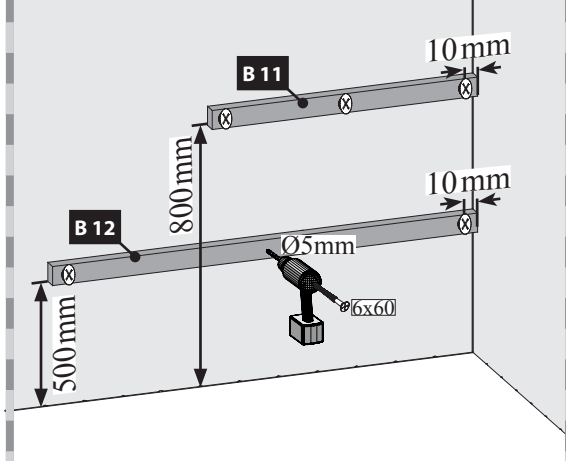
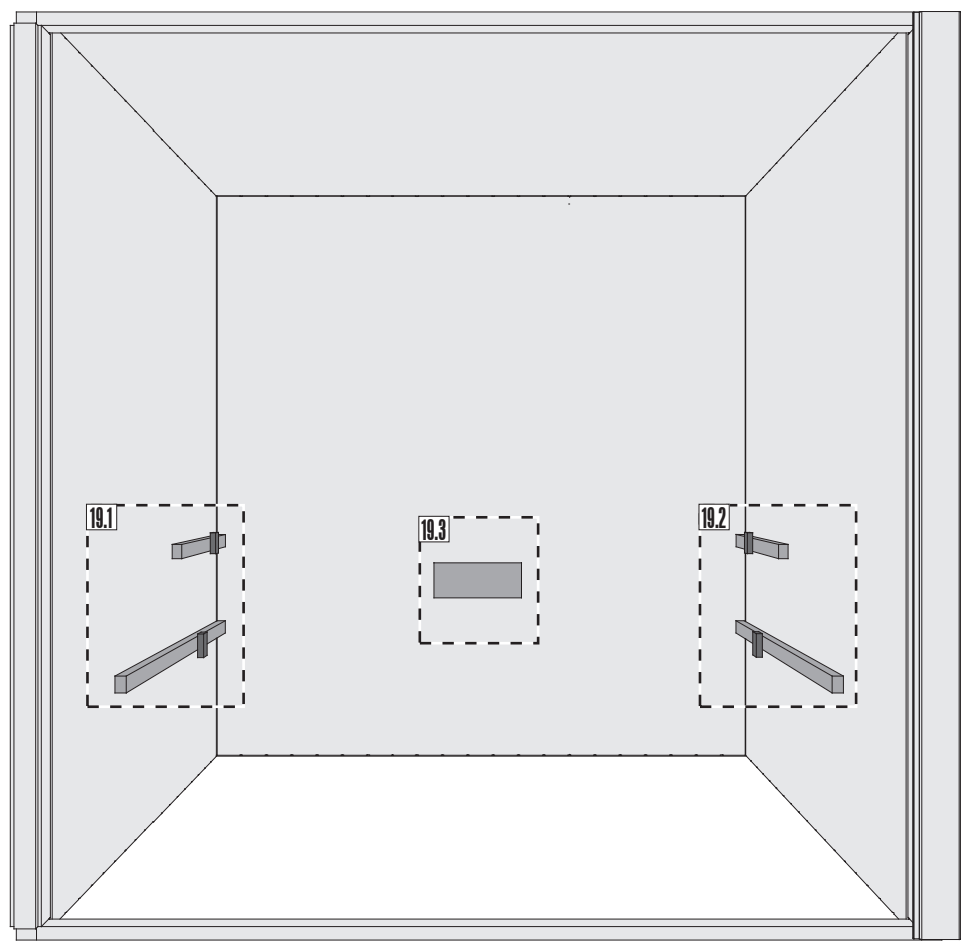

Tento obrázek znázorňuje princip funkce desky.
Regulujte výstup vzduchu podle vlastních představ.

Tento obrázek znázorňuje princip funkce desky.
Regulujte výstup vzduchu podľa vlastných predstáv.

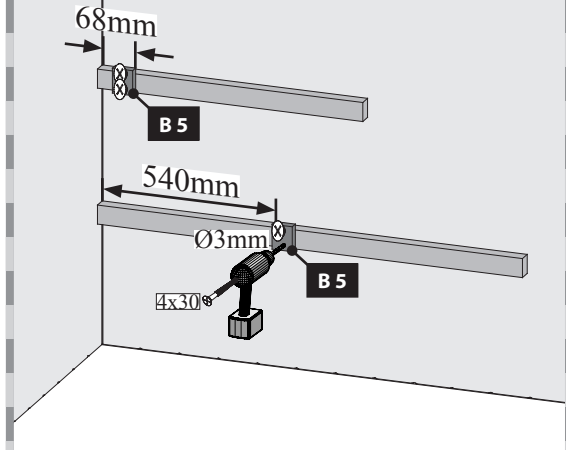
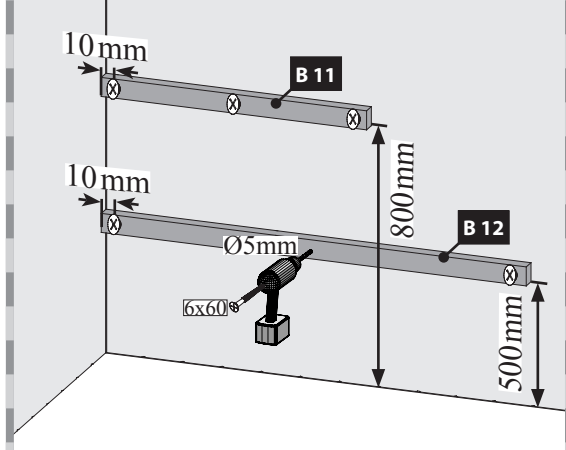

20 2x

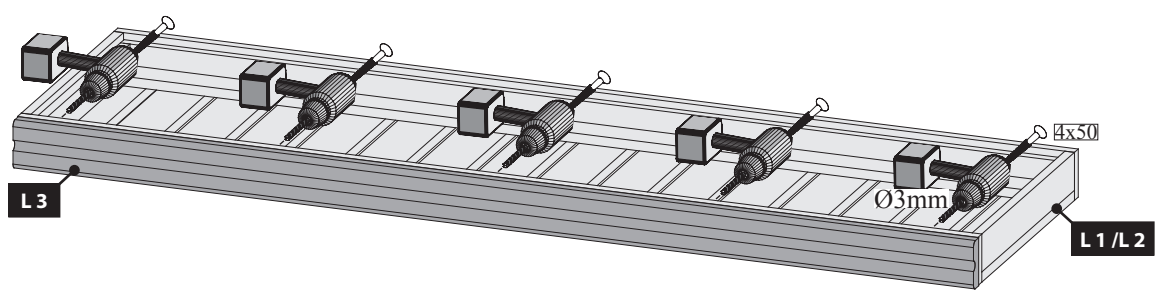
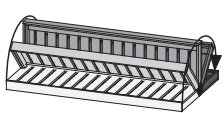

21 2x

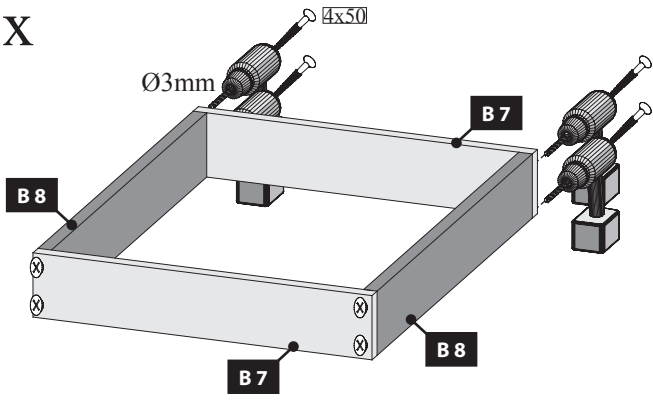

22

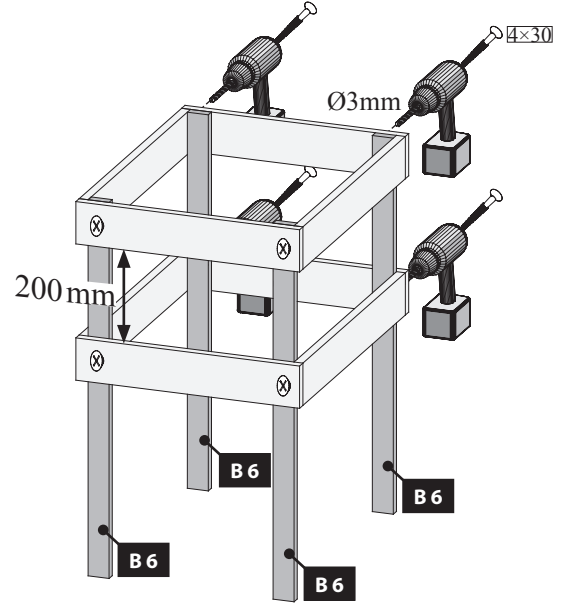

23

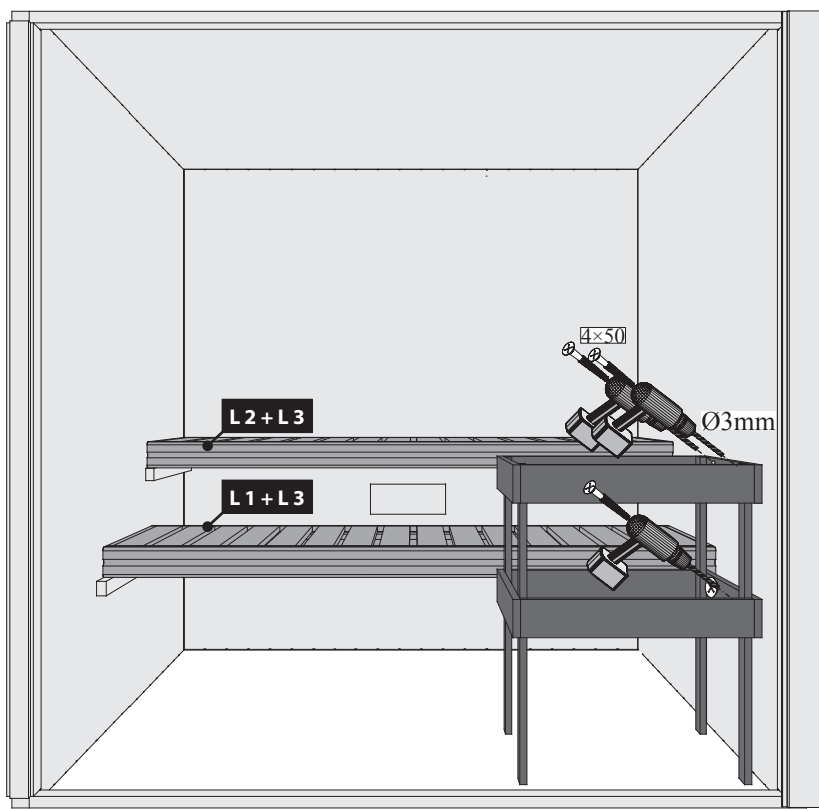

24

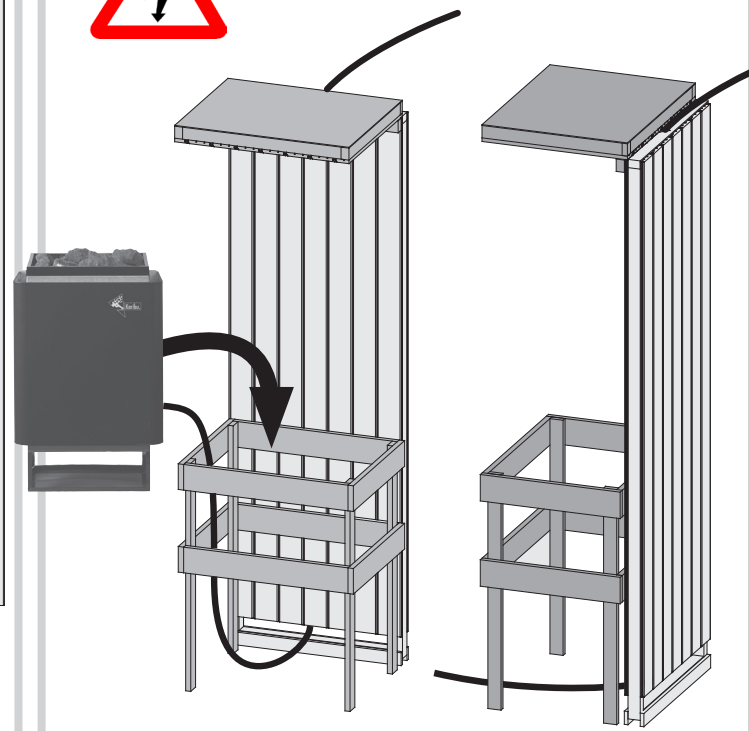
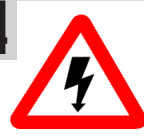

Pokračujte v sestavování skleněných dveří - viz dále.
Pokračujte v zostavování skleněných dverí - vid' ďalej.

!!! 04 — 08 !!!

01

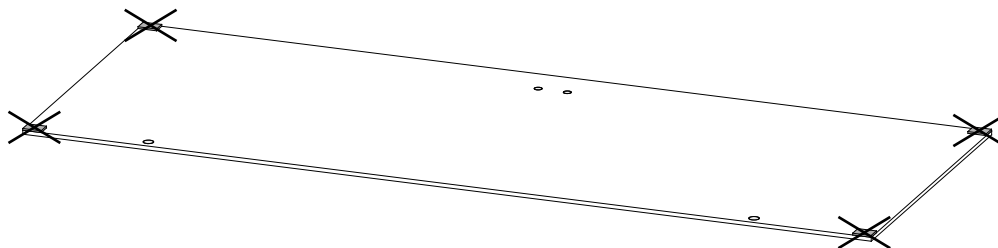

02

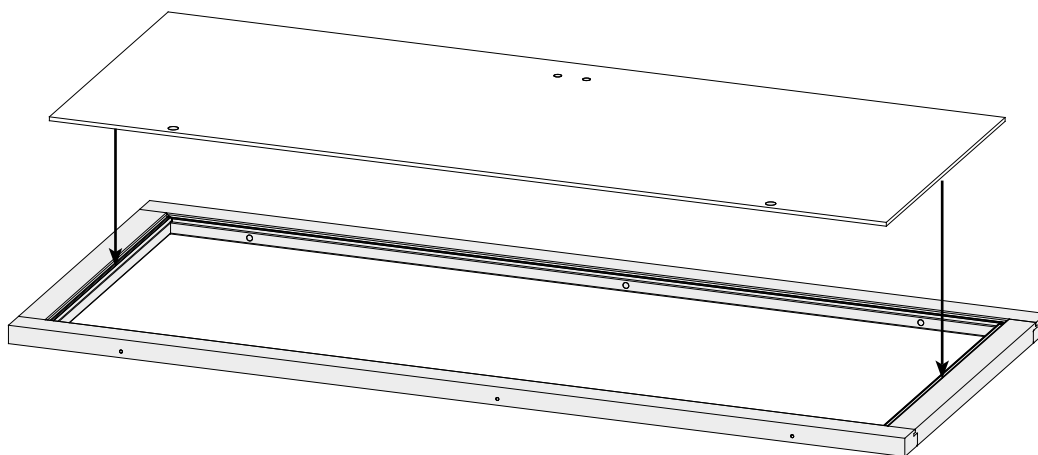

03

Vyrovnejte sklo saunových dveří v rámu!

Vyrovnejte sklo saunových dveří v rámu!

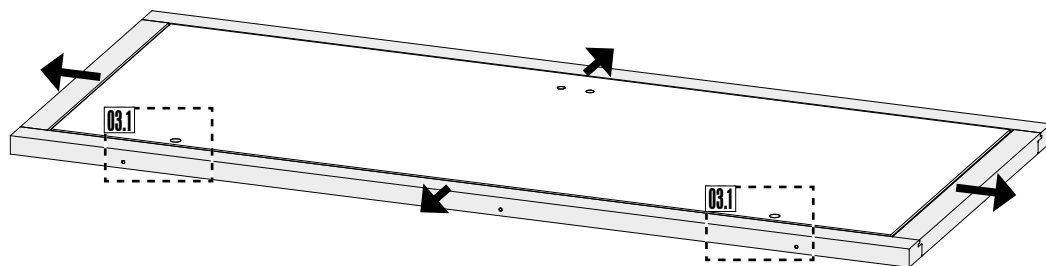

03.1-1

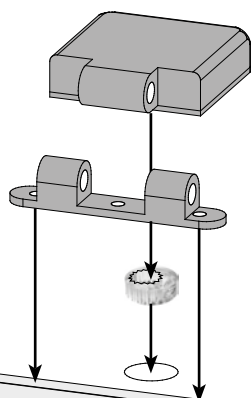

03.1-2

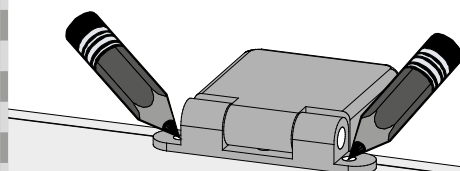

03.1-3

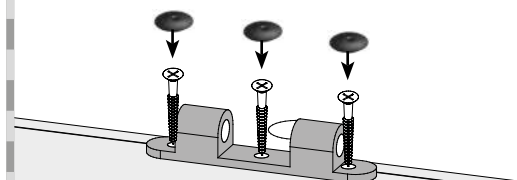

04

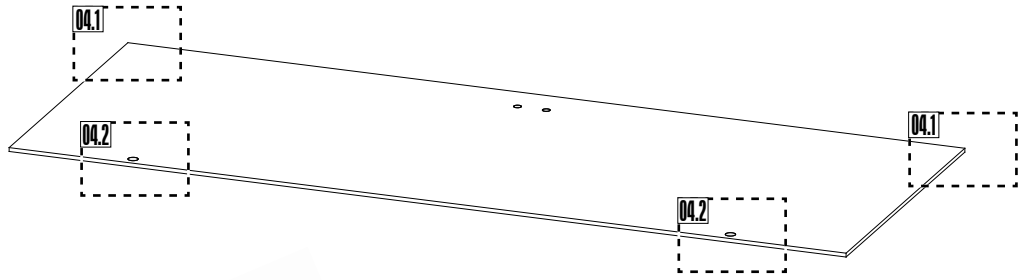

04.1-1

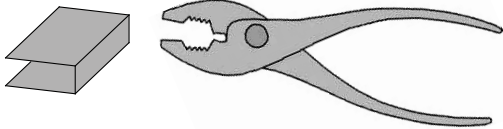

04.1-2

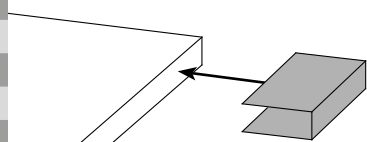

04.1-3

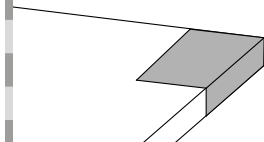

04.2-1

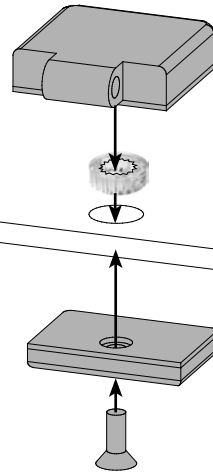

04.2-2

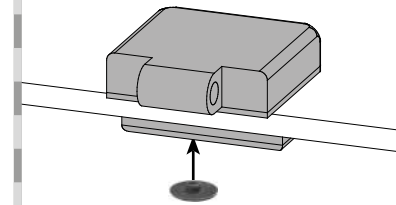

05

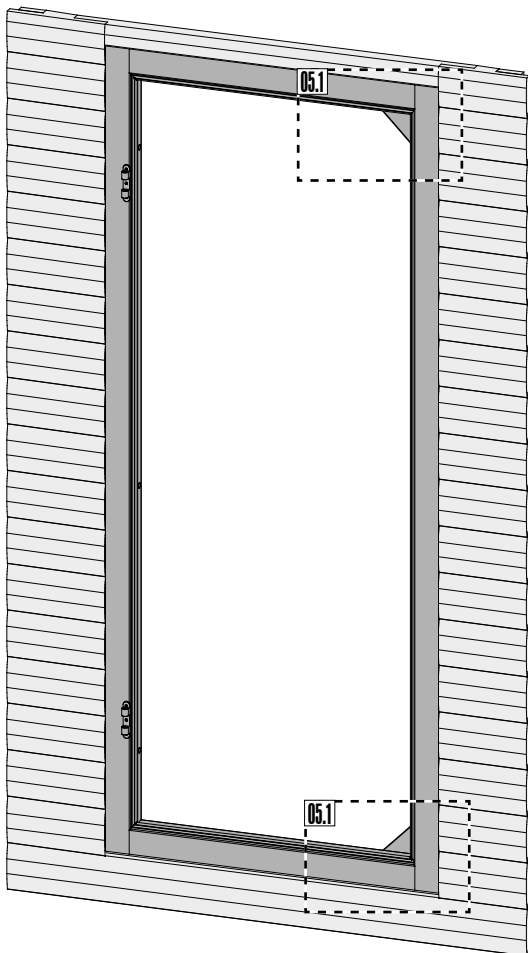

Pozor:
Všechny nastavitelné excentry musejí být na skle ve stejné zadní poloze!



Pozor:
Všetky nastavitelné excentre musia byť na skle v rovnakej zadnej polohe!



05.1-1

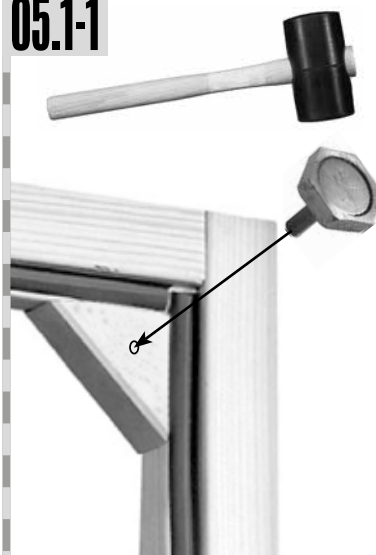

05.1-2



Montáž skleněných dveří

Montáž skleněných dveří

06

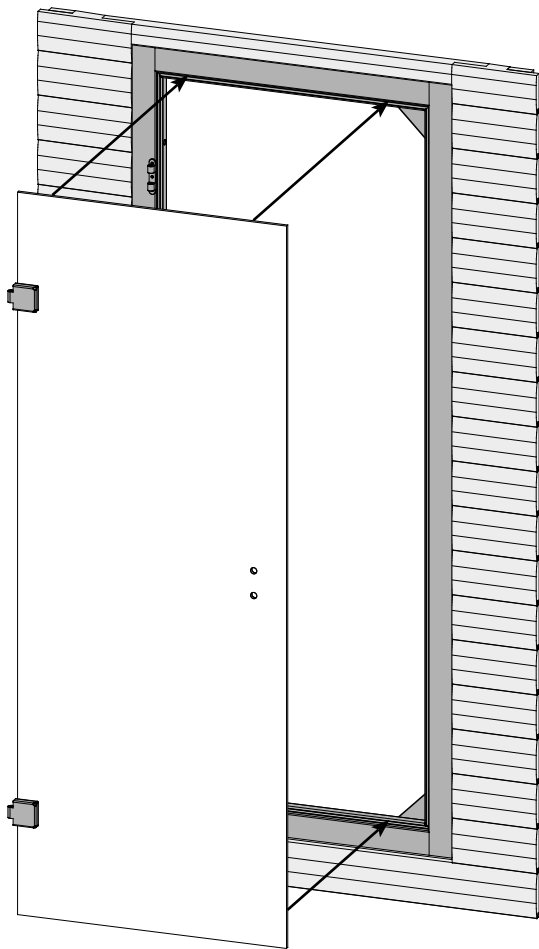

07

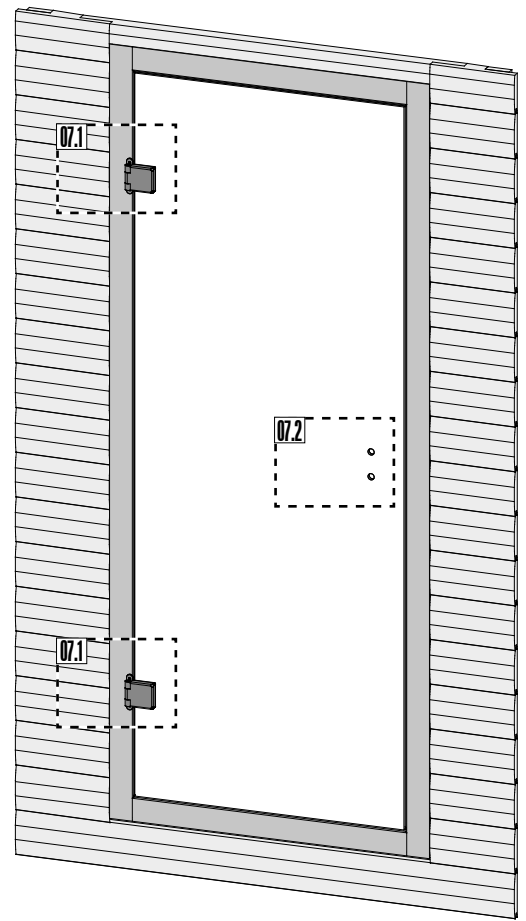

07.1

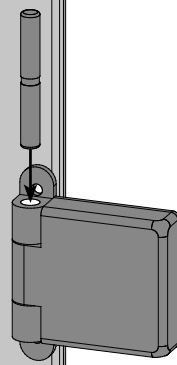

07.2-1

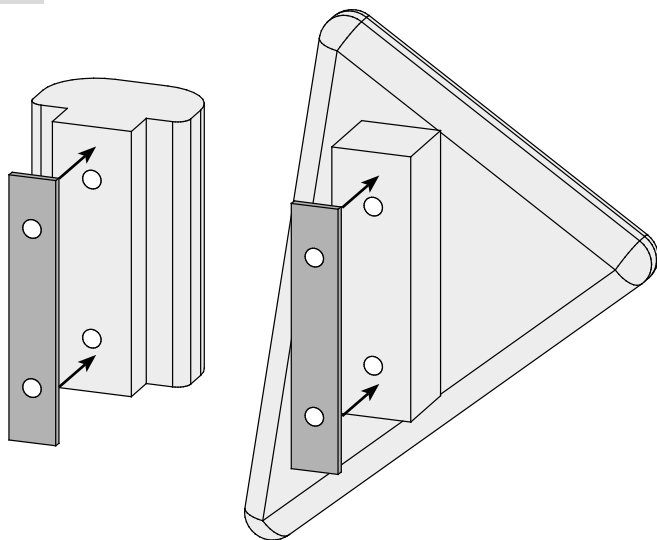

07.2-2

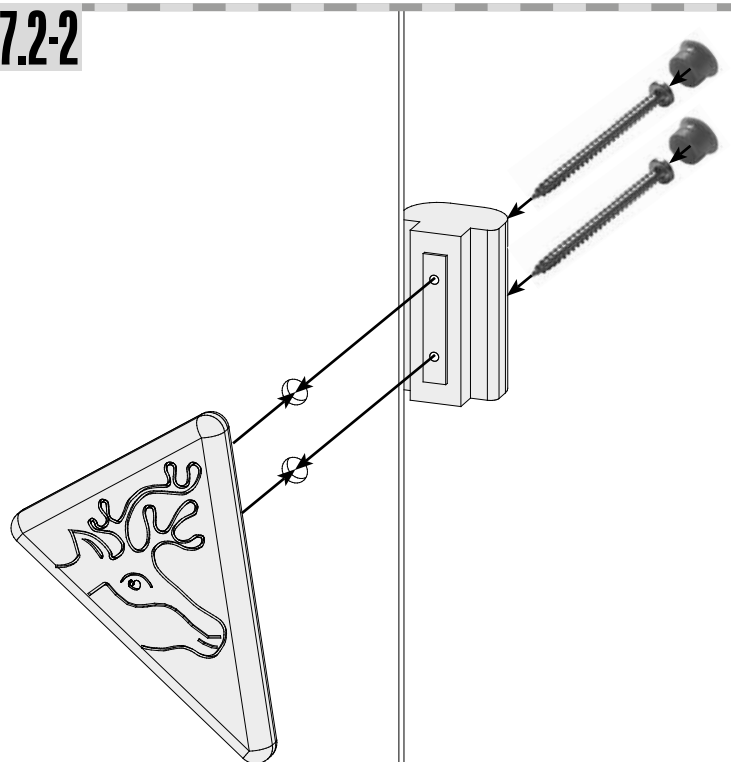

Boční + výškové nastavení

Pozor: Všechny nastavitelné excentry musejí být na skle ve stejné zadní poloze!

Bočné + výškové nastavenie

Pozor: Všetky nastavitelné excentre musia byť na skle v rovnakej zadnej polohe!

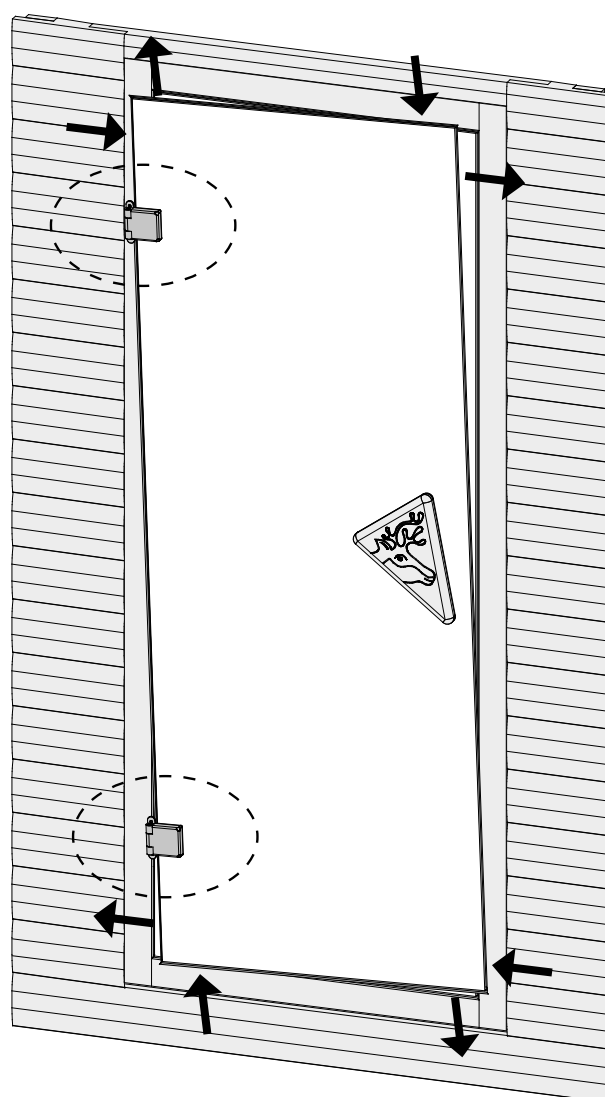
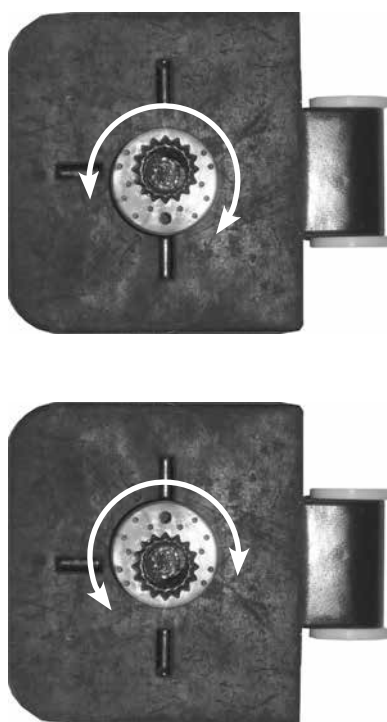

Zajištění kabeláže

Zaistenie kabeláže

Kamna - uvnitř

Pec - vnútri

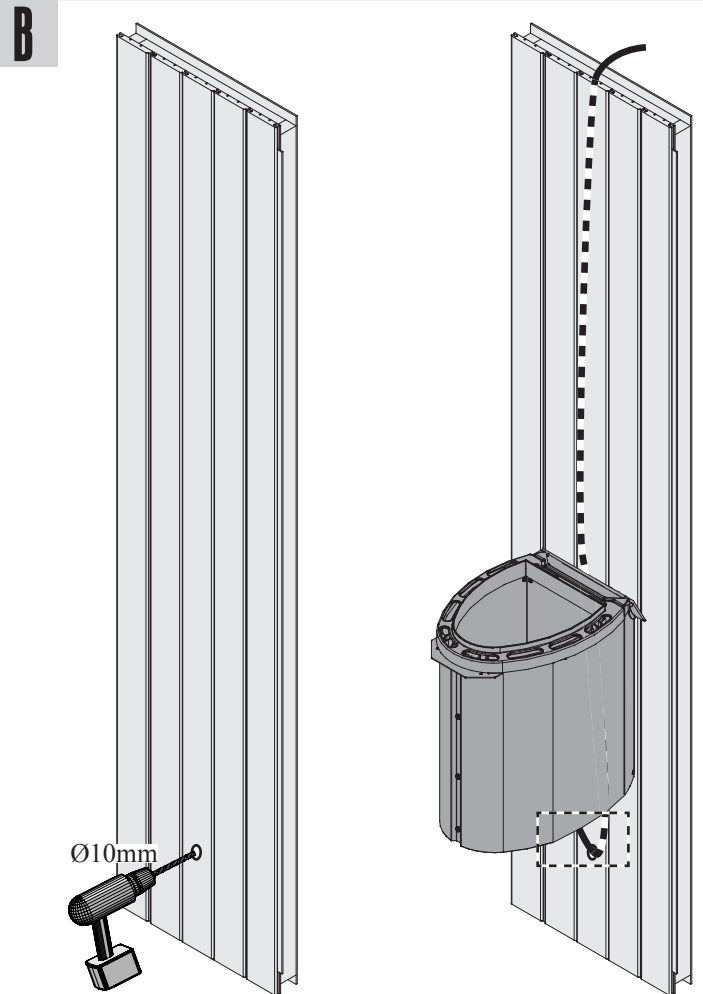
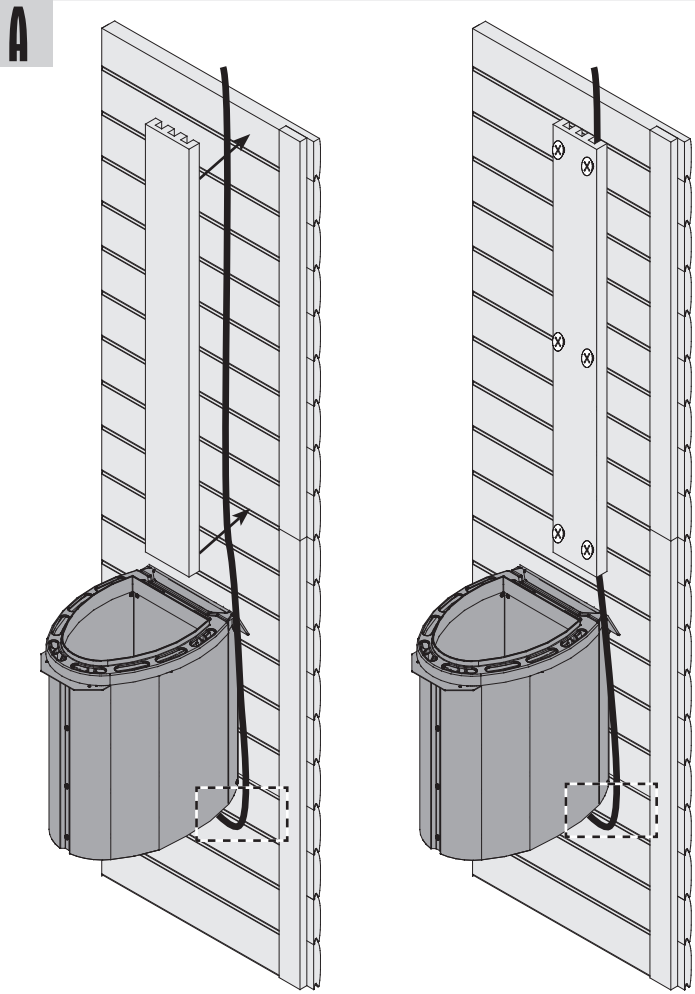

Zajištění kabeláže

Zaistenie kabeláže

Osvětlení - uvnitř

Osvetlenie - vnútri

Ovládací panel - vně

Ovládací panel - zvonka

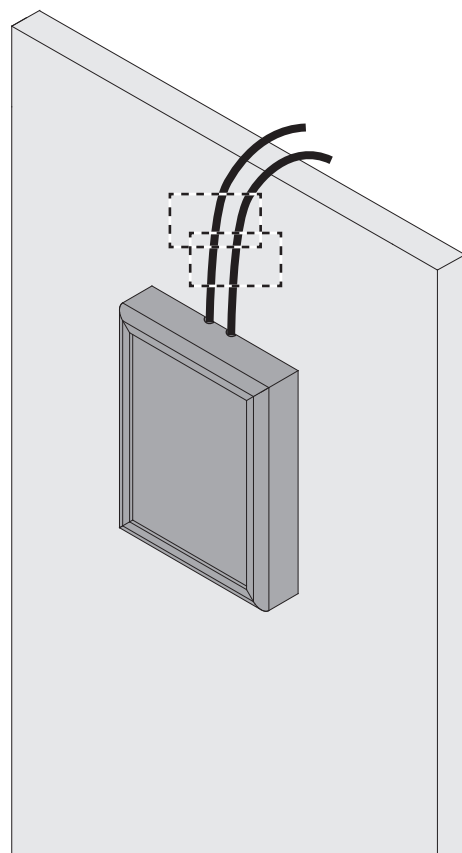
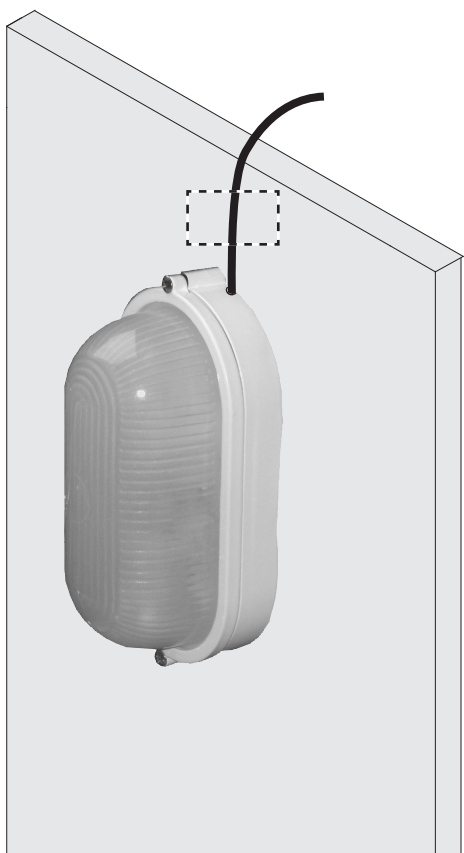

1

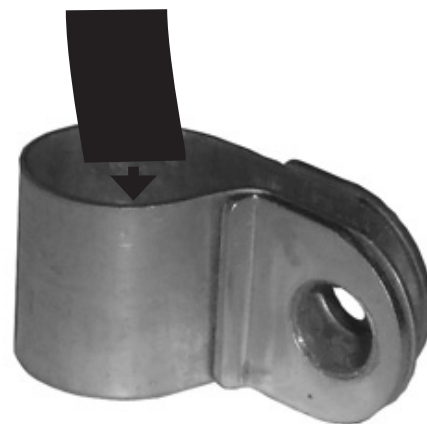

2



01

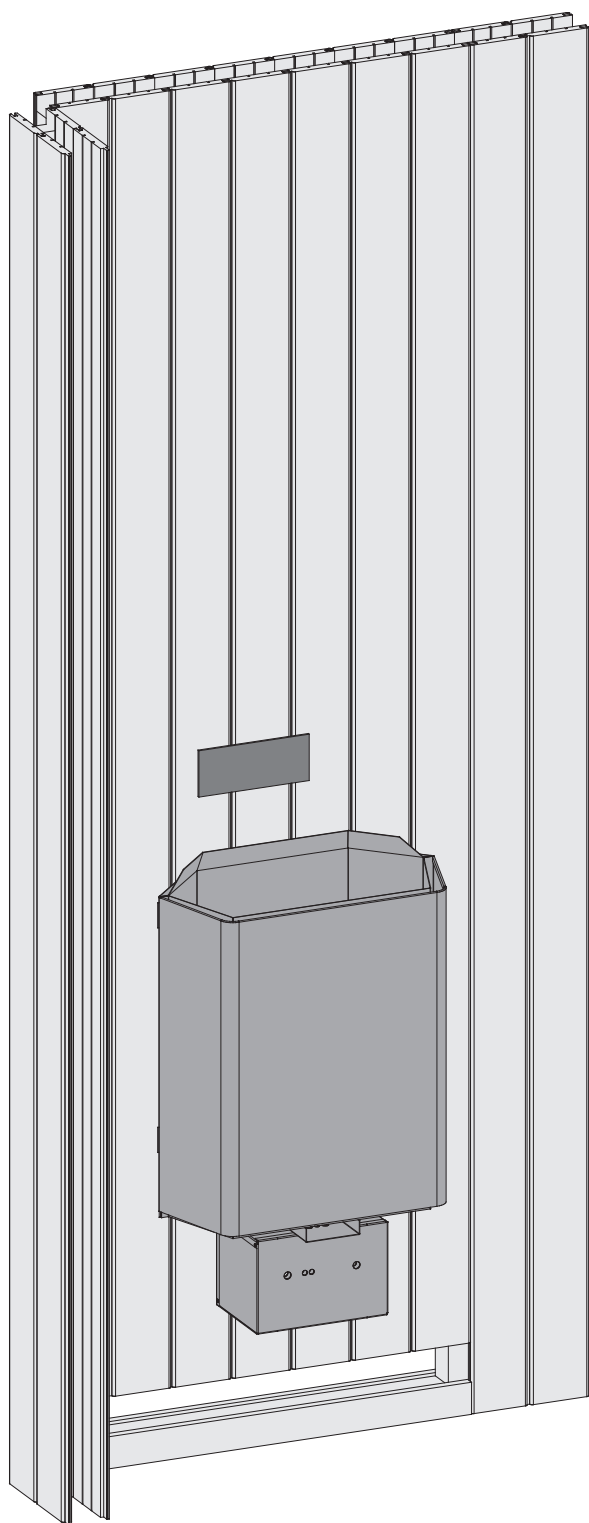

02

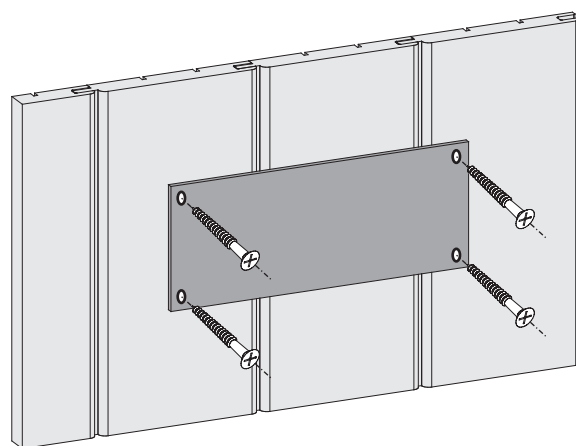

Nechejte si Vaše saunová kamna zapojit odborným elektrikářem. Ten označí zapojená kamna přiloženým štítkem zkušebny TÜV. Štítek by měl být umístěn na dobře viditelném místě nad kamny.

Nečajte si Vašu saunovú pec zapojiť odborným elektrikárom. Ten označí zapojenú pec priloženým štítkom zkušobne TÜV. Štítok by mal byť umiestený na dobre viditeľnom mieste nad pecou.

